

PHC-A

Power Hydro Chuck

● Hydro chuck with collet holder flexibility. Suitable for high precision cutting.

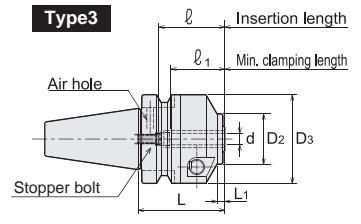
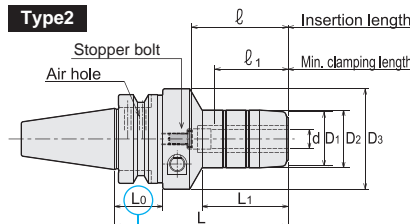
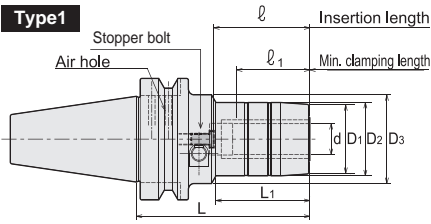

For PHC04A, the Stopper bolt is not included. Please order separately (Special item).

Caution
★ : Take precautions against A.T.C. interference.

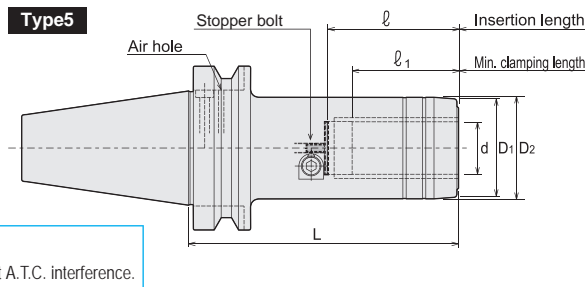
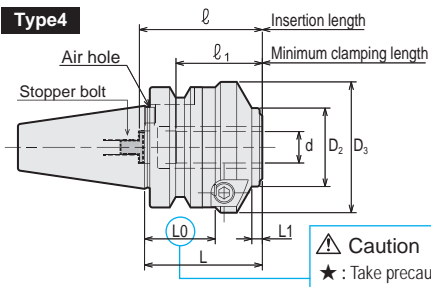

Caution
★ : Take precautions against A.T.C. interference.

Metric Sizes

Unit : Metric

| Code | Model | Type | d | L | L1 | D1 | D2 | D3 | L0 | ℓ | ℓ1 | Kg | Hex. Wrench (Option) |
|---------------|------------------|------|----|-----|------|----|----|----|----|----|----|-----|----------------------|
| 3930 01104065 | BT30 -PHC04A -65 | 1 | 4 | 65 | 25.1 | — | 25 | 46 | — | 29 | 24 | | L-4T (4mm) |
| 3930 01106045 | BT30 -PHC06A -45 | 3 | 6 | 45 | 4 | — | 26 | 46 | — | 34 | 29 | 0.6 | |
| 3930 01106075 | -75 | 1 | 6 | 75 | 30 | 24 | 26 | 46 | — | 34 | 29 | 0.7 | |
| 3930 01107045 | BT30 -PHC07A -45 | 3 | 7 | 45 | 4 | — | 28 | 46 | — | 34 | 29 | 0.6 | |
| 3930 01107075 | -75 | 1 | 7 | 75 | 30 | 26 | 28 | 46 | — | 34 | 29 | 0.8 | |
| 3930 01108045 | BT30 -PHC08A -45 | 3 | 8 | 45 | 4 | — | 28 | 46 | — | 34 | 29 | 0.6 | |
| 3930 01108075 | -75 | 1 | 8 | 75 | 30 | 26 | 28 | 46 | — | 34 | 29 | 0.8 | |
| 3930 01109045 | BT30 -PHC09A -45 | 3 | 9 | 45 | 4 | — | 30 | 46 | — | 45 | 33 | 0.6 | |
| 3930 01109090 | -90 | 1 | 9 | 90 | 46 | 28 | 30 | 46 | — | 55 | 40 | 0.8 | |
| 3930 01109105 | -105 | 2 | 9 | 105 | 44 | 28 | 30 | 52 | 40 | 50 | 40 | 1.2 | |
| 3930 01110045 | BT30 -PHC10A -45 | 3 | 10 | 45 | 4 | — | 30 | 46 | — | 45 | 33 | 0.6 | |
| 3930 01110090 | -90 | 1 | 10 | 90 | 46 | 28 | 30 | 46 | — | 55 | 40 | 0.8 | |
| 3930 01110105 | -105 | 2 | 10 | 105 | 44 | 28 | 30 | 52 | 40 | 50 | 40 | 1.2 | |
| 3930 01111045 | BT30 -PHC11A -45 | 3 | 11 | 45 | 4 | — | 30 | 46 | — | 45 | 33 | 0.6 | |
| 3930 01111090 | -90 | 1 | 11 | 90 | 46 | 30 | 32 | 46 | — | 55 | 40 | 0.9 | |
| 3930 01111105 | -105 | 2 | 11 | 105 | 45 | 30 | 32 | 52 | 40 | 50 | 40 | 1.1 | |
| 3930 01112045 | BT30 -PHC12A -45 | 3 | 12 | 45 | 4 | — | 30 | 46 | — | 45 | 33 | 0.6 | |
| 3930 01112090 | -90 | 1 | 12 | 90 | 46 | 30 | 32 | 46 | — | 55 | 40 | 0.9 | |
| 3930 01112105 | -105 | 2 | 12 | 105 | 45 | 30 | 32 | 52 | 40 | 50 | 40 | 1.1 | |
| 3930 01113045 | BT30 -PHC13A -45 | 4 | 13 | 45 | 4 | — | 30 | 50 | 27 | 45 | 33 | 0.6 | |
| 3930 01113090 | -90 | 1 | 13 | 90 | 48 | 34 | 36 | 46 | — | 55 | 40 | 0.9 | |
| 3930 01113105 | -105 | 2 | 13 | 105 | 46 | 34 | 36 | 52 | 40 | 50 | 40 | 1.5 | |
| 3930 01114045 | BT30 -PHC14A -45 | 4 | 14 | 45 | 4 | — | 30 | 50 | 27 | 45 | 33 | 0.6 | |
| 3930 01114090 | -90 | 1 | 14 | 90 | 48 | 34 | 36 | 46 | — | 55 | 40 | 0.9 | |
| 3930 01114105 | -105 | 2 | 14 | 105 | 46 | 34 | 36 | 52 | 40 | 50 | 40 | 1.2 | |
| 3930 01115045 | BT30 -PHC15A -45 | 4 | 15 | 45 | 4 | — | 30 | 50 | 27 | 45 | 33 | 0.6 | |
| 3930 01115090 | -90 | 1 | 15 | 90 | 48 | 36 | 38 | 46 | — | 55 | 40 | 1.0 | |
| 3930 01115105 | -105 | 2 | 15 | 105 | 46 | 36 | 38 | 52 | 40 | 50 | 40 | 1.2 | |
| 3930 01116045 | BT30 -PHC16A -45 | 4 | 16 | 45 | 4 | — | 30 | 50 | 27 | 45 | 33 | 0.6 | |
| 3930 01116090 | -90 | 1 | 16 | 90 | 48 | 36 | 38 | 46 | — | 55 | 40 | 0.9 | |
| 3930 01116105 | -105 | 2 | 16 | 105 | 46 | 36 | 38 | 52 | 40 | 50 | 40 | 1.2 | |
| 3930 01120090 | BT30 -PHC20A -90 | 1 | 20 | 90 | 49 | 40 | 42 | 46 | — | 50 | 40 | 1.0 | |
| 3930 01120120 | -120 | 1 | 20 | 120 | 69 | 40 | 42 | 46 | — | 70 | 40 | 1.3 | |
| 3930 01304070 | BT40 -PHC04A -70 | 1 | 4 | 70 | 25.1 | — | 25 | 46 | — | 29 | 24 | | L-4T (4mm) |
| 3930 01306075 | BT40 -PHC06A -75 | 1 | 6 | 75 | 30 | 24 | 26 | 46 | — | 34 | 29 | 1.3 | |
| 3930 01306105 | -105 | 1 | 6 | 105 | 41 | 24 | 26 | 46 | — | 45 | 29 | 1.5 | |
| 3930 01307075 | BT40 -PHC07A -75 | 1 | 7 | 75 | 30 | 26 | 28 | 46 | — | 34 | 29 | 1.3 | |
| 3930 01307105 | -105 | 1 | 7 | 105 | 41 | 26 | 28 | 46 | — | 45 | 29 | 1.4 | |
| 3930 01308075 | BT40 -PHC08A -75 | 1 | 8 | 75 | 30 | 26 | 28 | 46 | — | 34 | 29 | 1.3 | |
| 3930 01308105 | -105 | 1 | 8 | 105 | 41 | 26 | 28 | 46 | — | 45 | 29 | 1.6 | |
| 3930 01309090 | BT40 -PHC09A -90 | 1 | 9 | 90 | 44 | 28 | 30 | 52 | — | 50 | 40 | 1.4 | |
| 3930 01309120 | -120 | 1 | 9 | 120 | 64 | 28 | 30 | 52 | — | 70 | 40 | 1.7 | |

Metric Sizes

Unit : Metric

| Code | Model | Type | d | L | L1 | D1 | D2 | D3 | L0 | ℓ | ℓ 1 | Kg | Hex. Wrench (Option) |
|---------------|-------------------|------|----|-----|-----|----|----|----|----|----|-----|-----|----------------------|
| 3930 01310090 | BT40 -PHC10A -90 | 1 | 10 | 90 | 44 | 28 | 30 | 52 | — | 50 | 40 | 1.4 | L-4T (4mm) |
| 3930 01310120 | -120 | 1 | 10 | 120 | 64 | 28 | 30 | 52 | — | 70 | 40 | 1.7 | |
| 3930 01311090 | BT40 -PHC11A -90 | 1 | 11 | 90 | 45 | 30 | 32 | 52 | — | 50 | 40 | 1.4 | |
| 3930 01311120 | -120 | 1 | 11 | 120 | 65 | 30 | 32 | 52 | — | 70 | 40 | 1.7 | |
| 3930 01312090 | BT40 -PHC12A -90 | 1 | 12 | 90 | 45 | 30 | 32 | 52 | — | 50 | 40 | 1.4 | |
| 3930 01312120 | -120 | 1 | 12 | 120 | 65 | 30 | 32 | 52 | — | 70 | 40 | 1.7 | |
| 3930 01313090 | BT40 -PHC13A -90 | 1 | 13 | 90 | 46 | 34 | 36 | 52 | — | 50 | 40 | 1.5 | |
| 3930 01313120 | -120 | 1 | 13 | 120 | 66 | 34 | 36 | 52 | — | 70 | 40 | 1.8 | |
| 3930 01314090 | BT40 -PHC14A -90 | 1 | 14 | 90 | 46 | 34 | 36 | 52 | — | 50 | 40 | 1.5 | |
| 3930 01314120 | -120 | 1 | 14 | 120 | 66 | 34 | 36 | 52 | — | 70 | 40 | 1.8 | |
| 3930 01315090 | BT40 -PHC15A -90 | 1 | 15 | 90 | 46 | 36 | 38 | 52 | — | 50 | 40 | 1.5 | |
| 3930 01315120 | -120 | 1 | 15 | 120 | 66 | 36 | 38 | 52 | — | 70 | 40 | 1.8 | |
| 3930 01316090 | BT40 -PHC16A -90 | 1 | 16 | 90 | 46 | 36 | 38 | 52 | — | 50 | 40 | 1.5 | |
| 3930 01316120 | -120 | 1 | 16 | 120 | 66 | 36 | 38 | 52 | — | 70 | 40 | 1.8 | |
| 3930 01320090 | BT40 -PHC20A -90 | 1 | 20 | 90 | 49 | 40 | 42 | 46 | — | 50 | 40 | 1.5 | |
| 3930 01320120 | -120 | 1 | 20 | 120 | 69 | 40 | 42 | 46 | — | 70 | 40 | 1.8 | |
| 3930 01325105 | BT40 -PHC25A -105 | 1 | 25 | 105 | 59 | 50 | 52 | 62 | — | 60 | 50 | 2.1 | |
| 3930 01325135 | -135 | 1 | 25 | 135 | 79 | 50 | 52 | 62 | — | 80 | 50 | 2.5 | |
| 3930 01332120 | BT40 -PHC32A -120 | 5 | 32 | 120 | 93 | 60 | 62 | — | — | 75 | 65 | 2.6 | |
| 3930 01332150 | -150 | 5 | 32 | 150 | 123 | 60 | 62 | — | — | 80 | 65 | 3.2 | |
| 3930 01506090 | BT50 -PHC06A -90 | 1 | 6 | 90 | 30 | 24 | 26 | 46 | — | 34 | 29 | 3.8 | |
| 3930 01506120 | -120 | 1 | 6 | 120 | 41 | 24 | 26 | 46 | — | 45 | 29 | 4.1 | |
| 3930 01506150 | -150 | 1 | 6 | 150 | 41 | 24 | 26 | 46 | — | 45 | 29 | 4.4 | |
| 3930 01507090 | BT50 -PHC07A -90 | 1 | 7 | 90 | 30 | 26 | 28 | 46 | — | 34 | 29 | 3.9 | |
| 3930 01507120 | -120 | 1 | 7 | 120 | 41 | 26 | 28 | 46 | — | 45 | 29 | 4.1 | |
| 3930 01507150 | -150 | 1 | 7 | 150 | 41 | 26 | 28 | 46 | — | 45 | 29 | 4.5 | |
| 3930 01508090 | BT50 -PHC08A -90 | 1 | 8 | 90 | 30 | 26 | 28 | 46 | — | 34 | 29 | 3.9 | |
| 3930 01508120 | -120 | 1 | 8 | 120 | 41 | 26 | 28 | 46 | — | 45 | 29 | 4.1 | |
| 3930 01508150 | -150 | 1 | 8 | 150 | 41 | 26 | 28 | 46 | — | 45 | 29 | 4.5 | |
| 3930 01509105 | BT50 -PHC09A -105 | 1 | 9 | 105 | 44 | 28 | 30 | 52 | — | 50 | 40 | 4.0 | |
| 3930 01509135 | -135 | 1 | 9 | 135 | 64 | 28 | 30 | 52 | — | 70 | 40 | 4.3 | |
| 3930 01509165 | -165 | 1 | 9 | 165 | 64 | 28 | 30 | 52 | — | 70 | 40 | 4.7 | |
| 3930 01510105 | BT50 -PHC10A -105 | 1 | 10 | 105 | 44 | 28 | 30 | 52 | — | 50 | 40 | 4.1 | |
| 3930 01510135 | -135 | 1 | 10 | 135 | 64 | 28 | 30 | 52 | — | 70 | 40 | 4.3 | |
| 3930 01510165 | -165 | 1 | 10 | 165 | 64 | 28 | 30 | 52 | — | 70 | 40 | 4.7 | |
| 3930 01511105 | BT50 -PHC11A -105 | 1 | 11 | 105 | 45 | 30 | 32 | 52 | — | 50 | 40 | 4.1 | |
| 3930 01511135 | -135 | 1 | 11 | 135 | 65 | 30 | 32 | 52 | — | 70 | 40 | 4.3 | |
| 3930 01511165 | -165 | 1 | 11 | 165 | 65 | 30 | 32 | 52 | — | 70 | 40 | 4.7 | |
| 3930 01512105 | BT50 -PHC12A -105 | 1 | 12 | 105 | 45 | 30 | 32 | 52 | — | 50 | 40 | 4.1 | |
| 3930 01512135 | -135 | 1 | 12 | 135 | 65 | 30 | 32 | 52 | — | 70 | 40 | 4.3 | |
| 3930 01512165 | -165 | 1 | 12 | 165 | 65 | 30 | 32 | 52 | — | 70 | 40 | 4.7 | |
| 3930 01513105 | BT50 -PHC13A -105 | 1 | 13 | 105 | 46 | 34 | 36 | 52 | — | 50 | 40 | 4.2 | |
| 3930 01513135 | -135 | 1 | 13 | 135 | 66 | 34 | 36 | 52 | — | 70 | 40 | 4.4 | |
| 3930 01513165 | -165 | 1 | 13 | 165 | 66 | 34 | 36 | 52 | — | 70 | 40 | 4.8 | |
| 3930 01514105 | BT50 -PHC14A -105 | 1 | 14 | 105 | 46 | 34 | 36 | 52 | — | 50 | 40 | 4.1 | |
| 3930 01514135 | -135 | 1 | 14 | 135 | 66 | 34 | 36 | 52 | — | 70 | 40 | 4.4 | |
| 3930 01514165 | -165 | 1 | 14 | 165 | 66 | 34 | 36 | 52 | — | 70 | 40 | 4.8 | |
| 3930 01515105 | BT50 -PHC15A -105 | 1 | 15 | 105 | 46 | 36 | 38 | 52 | — | 50 | 40 | 4.1 | |
| 3930 01515135 | -135 | 1 | 15 | 135 | 66 | 36 | 38 | 52 | — | 70 | 40 | 4.4 | |
| 3930 01515165 | -165 | 1 | 15 | 165 | 66 | 36 | 38 | 52 | — | 70 | 40 | 4.8 | |
| 3930 01516105 | BT50 -PHC16A -105 | 1 | 16 | 105 | 46 | 36 | 38 | 52 | — | 50 | 40 | 4.1 | |
| 3930 01516135 | -135 | 1 | 16 | 135 | 66 | 36 | 38 | 52 | — | 70 | 40 | 4.4 | |
| 3930 01516165 | -165 | 1 | 16 | 165 | 66 | 36 | 38 | 52 | — | 70 | 40 | 4.8 | |
| 3930 01520105 | BT50 -PHC20A -105 | 1 | 20 | 105 | 49 | 40 | 42 | 46 | — | 50 | 40 | 4.1 | |
| 3930 01520135 | -135 | 1 | 20 | 135 | 69 | 40 | 42 | 46 | — | 70 | 40 | 4.4 | |
| 3930 01520165 | -165 | 1 | 20 | 165 | 69 | 40 | 42 | 46 | — | 70 | 40 | 4.7 | |
| 3930 01525120 | BT50 -PHC25A -120 | 1 | 25 | 120 | 59 | 50 | 52 | 62 | — | 64 | 50 | 4.7 | |
| 3930 01525150 | -150 | 1 | 25 | 150 | 79 | 50 | 52 | 62 | — | 80 | 50 | 5.2 | |
| 3930 01525165 | -165 | 1 | 25 | 165 | 79 | 50 | 52 | 62 | — | 80 | 50 | 5.5 | |
| 3930 01532135 | BT50 -PHC32A -135 | 5 | 32 | 135 | — | 60 | 62 | — | — | 75 | 65 | 5.2 | |
| 3930 01532165 | -165 | 5 | 32 | 165 | — | 60 | 62 | — | — | 80 | 65 | 5.8 | |

- Cutting tool shank must be within tolerances specified below ;
Shank diameter less than 6mm : Within h6 tolerance
Shank diameter 6mm and over : Within h7 tolerance
h6 or 0/-0.01 tolerance is recommended when newly making a cutting tool.
- Do not leave the holder with actuating screw tightened when the chuck is empty.
- PHC12A and PHC20A have pin holes for collet with stopper pin on its body.
- Hex-head screws (included) are necessary to plug air hole for center through coolant feed.
- For PHC04A, the stopper bolt is not included. Please order separately (Special item).
- For PHC04A, the length adjustment unit cannot be used.

Ordering Example

BT40 - PHC 12 A - 135
 Shank size I.D. (d) Projection length (L)

| Tightening torque (Torque wrench : p.498) | | |
|---|----------|------------------------|
| model | I.D. (d) | Tightening torque (Nm) |
| | mm | |
| PHC-A | 06 ~ 08 | 11 ~ 12 |
| PHC-A | 09 ~ 20 | 7 ~ 8 |
| PHC-A | 25, 32 | 29 ~ 30 |

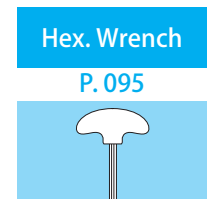
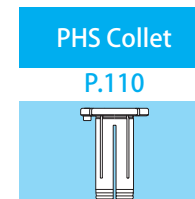

Length adjustment unit

Hex. Wrench for height adjustment

For shorter projection length

For longer projection length

| Shank size | Hex wrench size for height adjustment | Install / removal tool for length adjustment unit |
|------------|---------------------------------------|---|
| BT30 | 2.5mm | STS-R1 |
| BT40 | 2.5mm | STS-R2 |

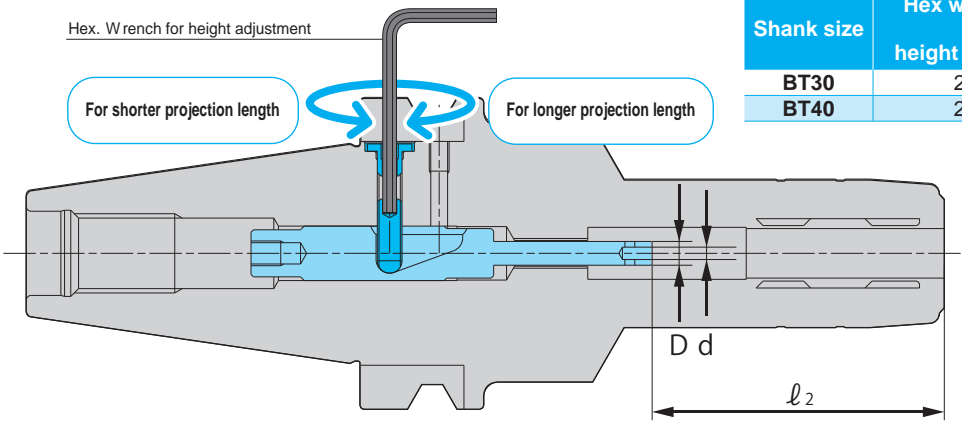

Metric Sizes

Unit : Metric

| Code | Length adjustment unit | Matched chuck | Adjustment range l_2 | Adjustable amount | Pin end I.D. (d) | Pin end O.D. (D) |
|---------------|------------------------|------------------|------------------------|-------------------|------------------|------------------|
| 3934 23044023 | PHC-P304-4023 | BT30 -PHC06A -75 | 29-34 | 5 | 2 | 3.8 |
| 3934 23044023 | PHC-P304-4023 | BT30 -PHC07A -75 | 29-34 | 5 | 2 | 3.8 |
| 3934 23044023 | PHC-P304-4023 | BT30 -PHC08A -75 | 29-34 | 5 | 2 | 3.8 |
| 3934 23053730 | PHC-P305-3730 | BT30 -PHC09A -90 | 40-45 | 5 | 2.5 | 4.8 |
| 3934 23053725 | PHC-P305-3725 | -90 | 45-50 | 5 | 2.5 | 4.8 |
| 3934 23053720 | PHC-P305-3720 | -90 | 50-55 | 5 | 2.5 | 4.8 |
| 3934 23054537 | PHC-P305-4537 | -105 | 40-45 | 5 | 2.5 | 4.8 |
| 3934 23054532 | PHC-P305-4532 | -105 | 45-50 | 5 | 2.5 | 4.8 |
| 3934 23053730 | PHC-P305-3730 | BT30 -PHC10A -90 | 40-45 | 5 | 2.5 | 4.8 |
| 3934 23053725 | PHC-P305-3725 | -90 | 45-50 | 5 | 2.5 | 4.8 |
| 3934 23053720 | PHC-P305-3720 | -90 | 50-55 | 5 | 2.5 | 4.8 |
| 3934 23054537 | PHC-P305-4537 | -105 | 40-45 | 5 | 2.5 | 4.8 |
| 3934 23054532 | PHC-P305-4532 | -105 | 45-50 | 5 | 2.5 | 4.8 |
| 3934 23053730 | PHC-P305-3730 | BT30 -PHC11A -90 | 40-45 | 5 | 2.5 | 4.8 |
| 3934 23053725 | PHC-P305-3725 | -90 | 45-50 | 5 | 2.5 | 4.8 |
| 3934 23053720 | PHC-P305-3720 | -90 | 50-55 | 5 | 2.5 | 4.8 |
| 3934 23054537 | PHC-P305-4537 | -105 | 40-45 | 5 | 2.5 | 4.8 |
| 3934 23054532 | PHC-P305-4532 | -105 | 45-50 | 5 | 2.5 | 4.8 |
| 3934 23053730 | PHC-P305-3730 | BT30 -PHC12A -90 | 40-45 | 5 | 2.5 | 4.8 |
| 3934 23053725 | PHC-P305-3725 | -90 | 45-50 | 5 | 2.5 | 4.8 |
| 3934 23053720 | PHC-P305-3720 | -90 | 50-55 | 5 | 2.5 | 4.8 |
| 3934 23054537 | PHC-P305-4537 | -105 | 40-45 | 5 | 2.5 | 4.8 |
| 3934 23054532 | PHC-P305-4532 | -105 | 45-50 | 5 | 2.5 | 4.8 |
| 3934 23053730 | PHC-P305-3730 | BT30 -PHC13A -90 | 40-45 | 5 | 2.5 | 4.8 |
| 3934 23053725 | PHC-P305-3725 | -90 | 45-50 | 5 | 2.5 | 4.8 |
| 3934 23053720 | PHC-P305-3720 | -90 | 50-55 | 5 | 2.5 | 4.8 |
| 3934 23054537 | PHC-P305-4537 | -105 | 40-45 | 5 | 2.5 | 4.8 |
| 3934 23054532 | PHC-P305-4532 | -105 | 45-50 | 5 | 2.5 | 4.8 |
| 3934 23053730 | PHC-P305-3730 | BT30 -PHC14A -90 | 40-45 | 5 | 2.5 | 4.8 |
| 3934 23053725 | PHC-P305-3725 | -90 | 45-50 | 5 | 2.5 | 4.8 |
| 3934 23053720 | PHC-P305-3720 | -90 | 50-55 | 5 | 2.5 | 4.8 |
| 3934 23054537 | PHC-P305-4537 | -105 | 40-45 | 5 | 2.5 | 4.8 |
| 3934 23054532 | PHC-P305-4532 | -105 | 45-50 | 5 | 2.5 | 4.8 |
| 3934 23053730 | PHC-P305-3730 | BT30 -PHC15A -90 | 40-45 | 5 | 2.5 | 4.8 |
| 3934 23053725 | PHC-P305-3725 | -90 | 45-50 | 5 | 2.5 | 4.8 |
| 3934 23053720 | PHC-P305-3720 | -90 | 50-55 | 5 | 2.5 | 4.8 |
| 3934 23054537 | PHC-P305-4537 | -105 | 40-45 | 5 | 2.5 | 4.8 |
| 3934 23054532 | PHC-P305-4532 | -105 | 45-50 | 5 | 2.5 | 4.8 |
| 3934 23053730 | PHC-P305-3730 | BT30 -PHC16A -90 | 40-45 | 5 | 2.5 | 4.8 |
| 3934 23053725 | PHC-P305-3725 | -90 | 45-50 | 5 | 2.5 | 4.8 |
| 3934 23053720 | PHC-P305-3720 | -90 | 50-55 | 5 | 2.5 | 4.8 |
| 3934 23054537 | PHC-P305-4537 | -105 | 40-45 | 5 | 2.5 | 4.8 |
| 3934 23054532 | PHC-P305-4532 | -105 | 45-50 | 5 | 2.5 | 4.8 |
| 3934 23054027 | PHC-P305-4027 | BT30 -PHC20A -90 | 40-45 | 5 | 2.5 | 4.8 |
| 3934 23054022 | PHC-P305-4022 | -90 | 45-50 | 5 | 2.5 | 4.8 |
| 3934 23054542 | PHC-P305-4542 | -120 | 50-55 | 5 | 2.5 | 4.8 |
| 3934 23054537 | PHC-P305-4537 | -120 | 55-60 | 5 | 2.5 | 4.8 |
| 3934 23054532 | PHC-P305-4532 | -120 | 60-65 | 5 | 2.5 | 4.8 |

Metric Sizes

Unit : Metric

| Code | Length adjustment unit | Matched chuck | Adjustment range ℓ 2 | Adjustable amount | Pin end I.D. (d) | Pin end O.D. (D) |
|---------------|------------------------|-------------------|---------------------------|-------------------|------------------|------------------|
| 3934 24044423 | PHC-P404-4423 | BT40 -PHC06A -75 | 29-34 | 5 | 2 | 3.8 |
| 3934 24046334 | PHC-P404-6334 | -105 | 29-39 | 10 | 2 | 3.8 |
| 3934 24046328 | PHC-P404-6328 | -105 | 35-45 | 10 | 2 | 3.8 |
| 3934 24044423 | PHC-P404-4423 | BT40 -PHC07A -75 | 29-34 | 5 | 2 | 3.8 |
| 3934 24046334 | PHC-P404-6334 | -105 | 29-39 | 10 | 2 | 3.8 |
| 3934 24046328 | PHC-P404-6328 | -105 | 35-45 | 10 | 2 | 3.8 |
| 3934 24044423 | PHC-P404-4423 | BT40 -PHC08A -75 | 29-34 | 5 | 2 | 3.8 |
| 3934 24046334 | PHC-P404-6334 | -105 | 29-39 | 10 | 2 | 3.8 |
| 3934 24046328 | PHC-P404-6328 | -105 | 35-45 | 10 | 2 | 3.8 |
| 3934 24054427 | PHC-P405-4427 | BT40 -PHC09A -90 | 40-50 | 10 | 2.5 | 4.8 |
| 3934 24054952 | PHC-P405-4952 | -120 | 40-50 | 10 | 2.5 | 4.8 |
| 3934 24054942 | PHC-P405-4942 | -120 | 50-60 | 10 | 2.5 | 4.8 |
| 3934 24054932 | PHC-P405-4932 | -120 | 60-70 | 10 | 2.5 | 4.8 |
| 3934 24054427 | PHC-P405-4427 | BT40 -PHC10A -90 | 40-50 | 10 | 2.5 | 4.8 |
| 3934 24054952 | PHC-P405-4952 | -120 | 40-50 | 10 | 2.5 | 4.8 |
| 3934 24054942 | PHC-P405-4942 | -120 | 50-60 | 10 | 2.5 | 4.8 |
| 3934 24054932 | PHC-P405-4932 | -120 | 60-70 | 10 | 2.5 | 4.8 |
| 3934 24054427 | PHC-P405-4427 | BT40 -PHC11A -90 | 40-50 | 10 | 2.5 | 4.8 |
| 3934 24054952 | PHC-P405-4952 | -120 | 40-50 | 10 | 2.5 | 4.8 |
| 3934 24054942 | PHC-P405-4942 | -120 | 50-60 | 10 | 2.5 | 4.8 |
| 3934 24054932 | PHC-P405-4932 | -120 | 60-70 | 10 | 2.5 | 4.8 |
| 3934 24054427 | PHC-P405-4427 | BT40 -PHC12A -90 | 40-50 | 10 | 2.5 | 4.8 |
| 3934 24054952 | PHC-P405-4952 | -120 | 40-50 | 10 | 2.5 | 4.8 |
| 3934 24054942 | PHC-P405-4942 | -120 | 50-60 | 10 | 2.5 | 4.8 |
| 3934 24054932 | PHC-P405-4932 | -120 | 60-70 | 10 | 2.5 | 4.8 |
| 3934 24054427 | PHC-P405-4427 | BT40 -PHC13A -90 | 40-50 | 10 | 2.5 | 4.8 |
| 3934 24054952 | PHC-P405-4952 | -120 | 40-50 | 10 | 2.5 | 4.8 |
| 3934 24054942 | PHC-P405-4942 | -120 | 50-60 | 10 | 2.5 | 4.8 |
| 3934 24054932 | PHC-P405-4932 | -120 | 60-70 | 10 | 2.5 | 4.8 |
| 3934 24054427 | PHC-P405-4427 | BT40 -PHC14A -90 | 40-50 | 10 | 2.5 | 4.8 |
| 3934 24054952 | PHC-P405-4952 | -120 | 40-50 | 10 | 2.5 | 4.8 |
| 3934 24054942 | PHC-P405-4942 | -120 | 50-60 | 10 | 2.5 | 4.8 |
| 3934 24054932 | PHC-P405-4932 | -120 | 60-70 | 10 | 2.5 | 4.8 |
| 3934 24054427 | PHC-P405-4427 | BT40 -PHC15A -90 | 40-50 | 10 | 2.5 | 4.8 |
| 3934 24054952 | PHC-P405-4952 | -120 | 40-50 | 10 | 2.5 | 4.8 |
| 3934 24054942 | PHC-P405-4942 | -120 | 50-60 | 10 | 2.5 | 4.8 |
| 3934 24054932 | PHC-P405-4932 | -120 | 60-70 | 10 | 2.5 | 4.8 |
| 3934 24054427 | PHC-P405-4427 | BT40 -PHC16A -90 | 40-50 | 10 | 2.5 | 4.8 |
| 3934 24054952 | PHC-P405-4952 | -120 | 40-50 | 10 | 2.5 | 4.8 |
| 3934 24054942 | PHC-P405-4942 | -120 | 50-60 | 10 | 2.5 | 4.8 |
| 3934 24054932 | PHC-P405-4932 | -120 | 60-70 | 10 | 2.5 | 4.8 |
| 3934 24054427 | PHC-P405-4427 | BT40 -PHC20A -90 | 40-50 | 10 | 2.5 | 4.8 |
| 3934 24054952 | PHC-P405-4952 | -120 | 40-50 | 10 | 2.5 | 4.8 |
| 3934 24054942 | PHC-P405-4942 | -120 | 50-60 | 10 | 2.5 | 4.8 |
| 3934 24054932 | PHC-P405-4932 | -120 | 60-70 | 10 | 2.5 | 4.8 |
| 3934 24054432 | PHC-P405-4432 | BT40 -PHC25A -105 | 50-60 | 10 | 2.5 | 4.8 |
| 3934 24055452 | PHC-P405-5452 | -135 | 50-60 | 10 | 2.5 | 4.8 |
| 3934 24055442 | PHC-P405-5442 | -135 | 60-70 | 10 | 2.5 | 4.8 |
| 3934 24055432 | PHC-P405-5432 | -135 | 70-80 | 10 | 2.5 | 4.8 |
| 3934 24054432 | PHC-P405-4432 | BT40 -PHC32A -120 | 65-75 | 10 | 2.5 | 4.8 |
| 3934 24055452 | PHC-P405-5452 | -150 | 65-75 | 10 | 2.5 | 4.8 |
| 3934 24054952 | PHC-P405-4952 | -150 | 70-80 | 10 | 2.5 | 4.8 |

Length adjustment unit can be used for chucks other than 45mm projection length.

Length adjustment unit can be used with BT, CAT and SK shank chucks only.

For PHC04A, the length adjustment unit cannot be used.

Ordering Example

BT30-PHC10A-105 with adjustment range of 40-45mm (Adjustable amount-5mm).

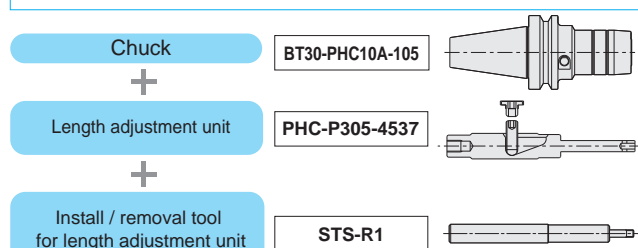

Length adjustment unit

Hex. Wrench for height adjustment

For shorter projection length

For longer projection length

| Shank size | Hex wrench size for height adjustment | Install / removal tool for length adjustment unit |
|------------|---------------------------------------|---|
| BT50 | 3mm | STS-R2 |

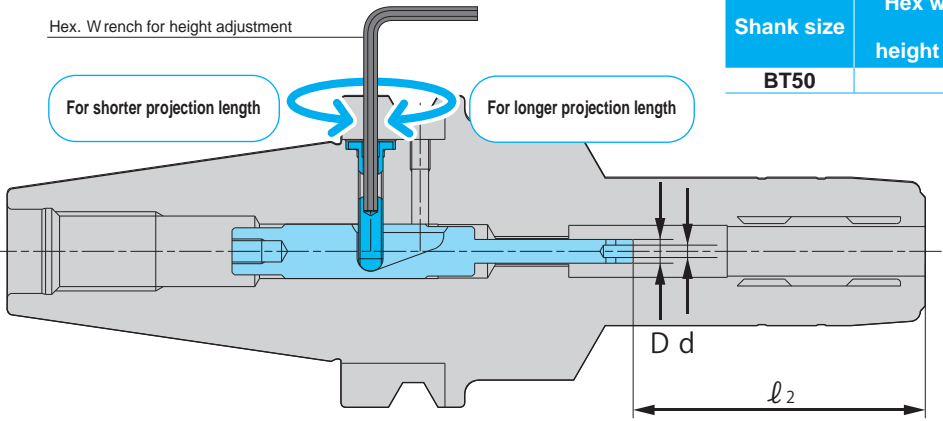

Metric Sizes

Unit : Metric

| Code | Length adjustment unit | Matched chuck | Adjustment range l_2 | Adjustable amount | Pin end I.D. (d) | Pin end O.D. (D) |
|---------------|------------------------|------------------|------------------------|-------------------|------------------|------------------|
| 3934 25045129 | PHC-P504-5129 | BT50 -PHC06A-90 | 29-34 | 5 | 2 | 3.8 |
| 3934 25047139 | PHC-P504-7139 | -120 | 29-45 | 16 | 2 | 3.8 |
| 3934 25040139 | PHC-P504-10139 | -150 | 29-45 | 16 | 2 | 3.8 |
| 3934 25045129 | PHC-P504-5129 | BT50 -PHC07A-90 | 29-34 | 5 | 2 | 3.8 |
| 3934 25047139 | PHC-P504-7139 | -120 | 29-45 | 16 | 2 | 3.8 |
| 3934 25040139 | PHC-P504-10139 | -150 | 29-45 | 16 | 2 | 3.8 |
| 3934 25045129 | PHC-P504-5129 | BT50 -PHC08A-90 | 29-34 | 5 | 2 | 3.8 |
| 3934 25047139 | PHC-P504-7139 | -120 | 29-45 | 16 | 2 | 3.8 |
| 3934 25040139 | PHC-P504-10139 | -150 | 29-45 | 16 | 2 | 3.8 |
| 3934 25055133 | PHC-P505-5133 | BT50 -PHC09A-105 | 40-50 | 10 | 2.5 | 4.8 |
| 3934 25056153 | PHC-P505-6153 | -135 | 40-55 | 15 | 2.5 | 4.8 |
| 3934 25056138 | PHC-P505-6138 | -135 | 55-70 | 15 | 2.5 | 4.8 |
| 3934 25059153 | PHC-P505-9153 | -165 | 40-55 | 15 | 2.5 | 4.8 |
| 3934 25059138 | PHC-P505-9138 | -165 | 55-70 | 15 | 2.5 | 4.8 |
| 3934 25055133 | PHC-P505-5133 | BT50 -PHC10A-105 | 40-50 | 10 | 2.5 | 4.8 |
| 3934 25056153 | PHC-P505-6153 | -135 | 40-55 | 15 | 2.5 | 4.8 |
| 3934 25056138 | PHC-P505-6138 | -135 | 55-70 | 15 | 2.5 | 4.8 |
| 3934 25059153 | PHC-P505-9153 | -165 | 40-55 | 15 | 2.5 | 4.8 |
| 3934 25059138 | PHC-P505-9138 | -165 | 55-70 | 15 | 2.5 | 4.8 |
| 3934 25055133 | PHC-P505-5133 | BT50 -PHC11A-105 | 40-50 | 10 | 2.5 | 4.8 |
| 3934 25056153 | PHC-P505-6153 | -135 | 40-55 | 15 | 2.5 | 4.8 |
| 3934 25056138 | PHC-P505-6138 | -135 | 55-70 | 15 | 2.5 | 4.8 |
| 3934 25059153 | PHC-P505-9153 | -165 | 40-55 | 15 | 2.5 | 4.8 |
| 3934 25059138 | PHC-P505-9138 | -165 | 55-70 | 15 | 2.5 | 4.8 |
| 3934 25055133 | PHC-P505-5133 | BT50 -PHC12A-105 | 40-50 | 10 | 2.5 | 4.8 |
| 3934 25056153 | PHC-P505-6153 | -135 | 40-55 | 15 | 2.5 | 4.8 |
| 3934 25056138 | PHC-P505-6138 | -135 | 55-70 | 15 | 2.5 | 4.8 |
| 3934 25059153 | PHC-P505-9153 | -165 | 40-55 | 15 | 2.5 | 4.8 |
| 3934 25059138 | PHC-P505-9138 | -165 | 55-70 | 15 | 2.5 | 4.8 |
| 3934 25055133 | PHC-P505-5133 | BT50 -PHC13A-105 | 40-50 | 10 | 2.5 | 4.8 |
| 3934 25056153 | PHC-P505-6153 | -135 | 40-55 | 15 | 2.5 | 4.8 |
| 3934 25056138 | PHC-P505-6138 | -135 | 55-70 | 15 | 2.5 | 4.8 |
| 3934 25059153 | PHC-P505-9153 | -165 | 40-55 | 15 | 2.5 | 4.8 |
| 3934 25059138 | PHC-P505-9138 | -165 | 55-70 | 15 | 2.5 | 4.8 |
| 3934 25055133 | PHC-P505-5133 | BT50 -PHC14A-105 | 40-50 | 10 | 2.5 | 4.8 |
| 3934 25056153 | PHC-P505-6153 | -135 | 40-55 | 15 | 2.5 | 4.8 |
| 3934 25056138 | PHC-P505-6138 | -135 | 55-70 | 15 | 2.5 | 4.8 |
| 3934 25059153 | PHC-P505-9153 | -165 | 40-55 | 15 | 2.5 | 4.8 |
| 3934 25059138 | PHC-P505-9138 | -165 | 55-70 | 15 | 2.5 | 4.8 |
| 3934 25055133 | PHC-P505-5133 | BT50 -PHC15A-105 | 40-50 | 10 | 2.5 | 4.8 |
| 3934 25056153 | PHC-P505-6153 | -135 | 40-55 | 15 | 2.5 | 4.8 |
| 3934 25056138 | PHC-P505-6138 | -135 | 55-70 | 15 | 2.5 | 4.8 |
| 3934 25059153 | PHC-P505-9153 | -165 | 40-55 | 15 | 2.5 | 4.8 |
| 3934 25059138 | PHC-P505-9138 | -165 | 55-70 | 15 | 2.5 | 4.8 |
| 3934 25055133 | PHC-P505-5133 | BT50 -PHC16A-105 | 40-50 | 10 | 2.5 | 4.8 |
| 3934 25056153 | PHC-P505-6153 | -135 | 40-55 | 15 | 2.5 | 4.8 |
| 3934 25056138 | PHC-P505-6138 | -135 | 55-70 | 15 | 2.5 | 4.8 |
| 3934 25059153 | PHC-P505-9153 | -165 | 40-55 | 15 | 2.5 | 4.8 |
| 3934 25059138 | PHC-P505-9138 | -165 | 55-70 | 15 | 2.5 | 4.8 |

Metric Sizes

Unit : Metric

| Code | Length adjustment unit | Matched chuck | Adjustment range ℓ 2 | Adjustable amount | Pin end I.D. (d) | Pin end O.D. (D) |
|---------------|------------------------|-------------------|---------------------------|-------------------|------------------|------------------|
| 3934 25055133 | PHC-P505-5133 | BT50 -PHC20A -105 | 40-50 | 10 | 2.5 | 4.8 |
| 3934 25056153 | PHC-P505-6153 | -135 | 40-55 | 15 | 2.5 | 4.8 |
| 3934 25056138 | PHC-P505-6138 | -135 | 55-70 | 15 | 2.5 | 4.8 |
| 3934 25059153 | PHC-P505-9153 | -165 | 40-55 | 15 | 2.5 | 4.8 |
| 3934 25059138 | PHC-P505-9138 | -165 | 55-70 | 15 | 2.5 | 4.8 |
| 3934 25055138 | PHC-P505-5138 | BT50 -PHC25A -120 | 50-64 | 14 | 2.5 | 4.8 |
| 3934 25056158 | PHC-P505-6158 | -150 | 50-65 | 15 | 2.5 | 4.8 |
| 3934 25056143 | PHC-P505-6143 | -150 | 65-80 | 15 | 2.5 | 4.8 |
| 3934 25057658 | PHC-P505-7658 | -165 | 50-65 | 15 | 2.5 | 4.8 |
| 3934 25057643 | PHC-P505-7643 | -165 | 65-80 | 15 | 2.5 | 4.8 |
| 3934 25055138 | PHC-P505-5138 | BT50 -PHC32A -135 | 65-75 | 10 | 2.5 | 4.8 |
| 3934 25056158 | PHC-P505-6158 | -165 | 65-80 | 15 | 2.5 | 4.8 |

Length adjustment unit can be used for chucks other than 45mm projection length.

Length adjustment unit can be used with BT, CAT and SK shank chucks only.

For PHC04A, the length adjustment unit cannot be used.

Ordering Example

BT50-PHC10A-105 with adjustment range of 40-45mm (Adjustable amount-5mm).

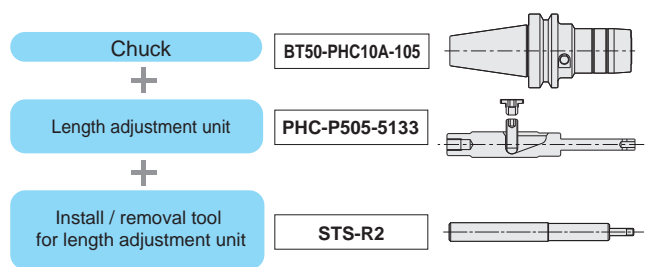

BT

BT

CAT

AHO

HSK-A/E/F/C

HSK-T

UTS

Specialized Machine

Related Equipment

Bush & Chamfering Drill

Milling Chuck

Collet Holder

"R" Zero Holder

Hydraulic Chuck

Shrink fit

Tapping Chuck

Arbors

Function Holder

Turning Tool

Retention Stud

Tool Shank Dimensions

Collet with stopper pin

Minimum clamping length for PHS

| Collet I.D. \square Metric | Collet I.D. \square Inch | Min. Clamping length Metric(Inch) |
|------------------------------|----------------------------|-----------------------------------|
| 3, 4 | 1/8 | 25 (0.984) |
| 5 | 3/16 | 30 (1.181) |
| 6, 7 | 5/16 | 34 (1.339) |
| 8, 9 | 7/16 | 38 (1.496) |
| 10, 11 | 9/16, 1/4 | 42 (1.654) |
| 12, 13, 14, 15, 16 | 3/8, 1/2, 5/8 | 50 (1.969) |

\square collet I.D. \square Model number

| \square | 1/8 | 3/16 | 1/4 | 5/16 | 3/8 | 7/16 | 1/2 | 9/16 | 5/8 |
|-----------|------|------|------|------|------|------|------|------|------|
| \square | 0125 | 0187 | 0250 | 0312 | 0375 | 0438 | 0500 | 0562 | 0625 |

For cutter with oil hole

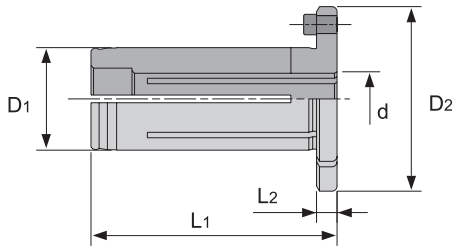

Ordering Example To hold $\phi 6$ cutting tool with BT40-PHC12A-120

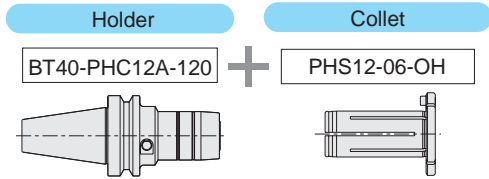

The collet with stopper pin can be used with PHC12A and PHC20A only.
The collet with stopper pin can be used with the length adjustment unit.

\square Metric , \square Metric

Unit : Metric

| Model | D1 | D2 | L1 | L2 | \square |
|----------------------|----|----|----|----|---|
| PHS12- \square -OH | 12 | 26 | 48 | 4 | 3, 4, 5, 6, 7, 8, 9, 10 |
| PHS20- \square -OH | 20 | 36 | 48 | 4 | 3, 4, 5, 6, 7, 8, 9, 10 11, 12, 13, 14, 15, 16 |

\square Metric , \square Inch

Unit : Inch

| Model | D1 | D2 | L1 | L2 | \square |
|----------------------|-------|-------|-------|-------|--|
| PHS12- \square -OH | 0.472 | 1.024 | 1.890 | 0.158 | 1/8, 3/16, 1/4, 5/16, 3/8 |
| PHS20- \square -OH | 0.787 | 1.418 | 1.890 | 0.158 | 1/8, 3/16, 1/4, 5/16, 3/8, 7/16, 1/2, 9/16, 5/8 |

\square Inch , \square Inch

Unit : Inch

| Model | D1 | D2 | L1 | L2 | \square |
|------------------------|-------|-------|-------|-------|--|
| PHS0500- \square -OH | 0.500 | 1.024 | 1.890 | 1.158 | 1/8, 3/16, 1/4, 5/16, 3/8 |
| PHS0750- \square -OH | 0.750 | 1.418 | 1.890 | 0.158 | 1/8, 3/16, 1/4, 5/16, 3/8, 7/16, 1/2, 9/16, 5/8 |

For collet through coolant

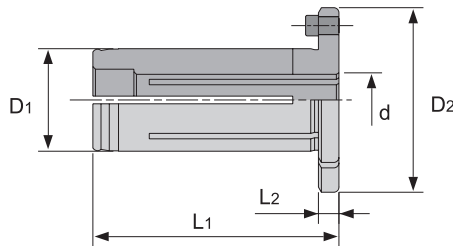

Ordering Example To hold $\phi 6$ cutting tool using collet through coolant feed with BT40-PHC12A-120

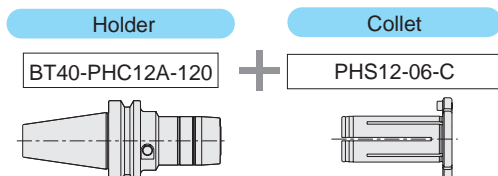

The collet with stopper pin can be used with PHC12A and PHC20A only.
The collet with stopper pin can be used with the length adjustment unit.

\square Metric , \square Metric

Unit : Metric

| Model | D1 | D2 | L1 | L2 | \square |
|---------------------|----|----|----|----|---|
| PHS12- \square -C | 12 | 26 | 48 | 4 | 3, 4, 5, 6, 7, 8, 9 |
| PHS20- \square -C | 20 | 36 | 48 | 4 | 3, 4, 5, 6, 7, 8, 9, 10 11, 12, 13, 14, 15, 16 |

\square Metric , \square Inch

Unit : Inch

| Model | D1 | D2 | L1 | L2 | \square |
|---------------------|-------|-------|-------|-------|--|
| PHS12- \square -C | 0.472 | 1.024 | 1.890 | 0.158 | 1/8, 3/16, 1/4, 5/16, 3/8 |
| PHS20- \square -C | 0.787 | 1.418 | 1.890 | 0.158 | 1/8, 3/16, 1/4, 5/16, 3/8, 7/16, 1/2, 9/16, 5/8 |

\square Inch , \square Inch

Unit : Inch

| Model | D1 | D2 | L1 | L2 | \square |
|-----------------------|-------|-------|-------|-------|--|
| PHS0500- \square -C | 0.500 | 1.024 | 1.890 | 1.158 | 1/8, 3/16, 1/4, 5/16, 3/8 |
| PHS0750- \square -C | 0.750 | 1.418 | 1.890 | 0.158 | 1/8, 3/16, 1/4, 5/16, 3/8, 7/16, 1/2, 9/16, 5/8 |

PHC-A

Power Hydro Chuck

- Hydro chuck with collet holder flexibility. Suitable for high precision cutting.

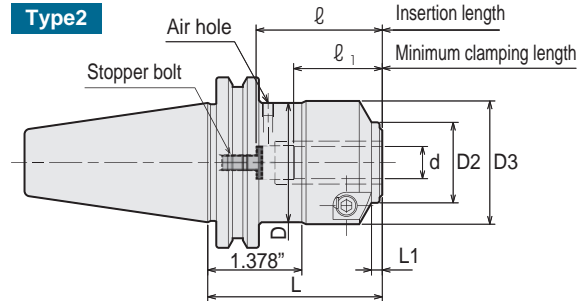
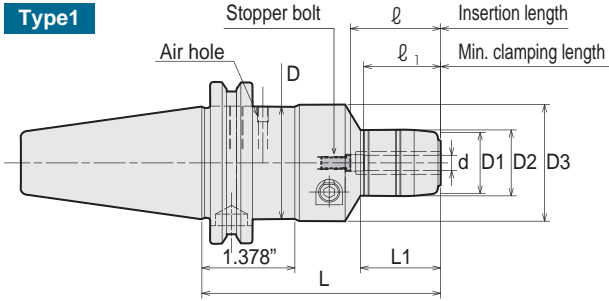

For PHC04A, the Stopper bolt is not included. Please order separately (Special item).

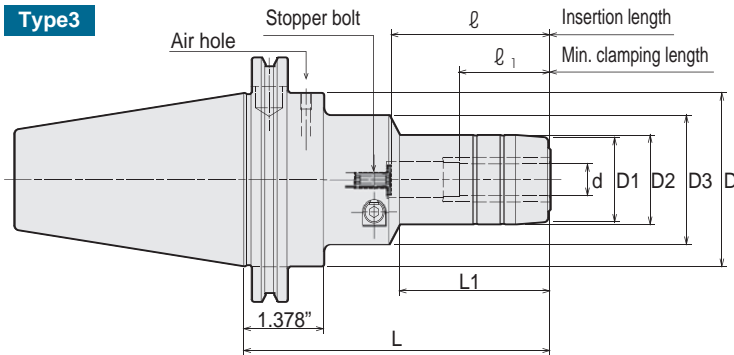

Inch Sizes

Unit : Inch

| Code | Model | Type | d | L | L1 | D | D1 | D2 | D3 | l | l1 | wrench (Option) |
|---------------|----------------------|------|-------|-------|-------|------|-------|-------|-------|-------|-------|-----------------|
| 1860 11408065 | CAT40 -PHC0250A -65 | 2 | 0.25 | 2.56 | 0.158 | 1.75 | — | 1.024 | 1.807 | 1.338 | 1.142 | L-4T (4mm) |
| 1860 11408090 | -90 | 1 | 0.25 | 3.544 | 1.19 | 1.75 | 0.945 | 1.024 | 1.811 | 1.338 | 1.142 | |
| 1860 11408120 | -120 | 1 | 0.25 | 4.725 | 1.623 | 1.75 | 0.945 | 1.024 | 1.811 | 1.771 | 1.142 | |
| 1860 11410065 | CAT40 -PHC0312A -65 | 2 | 0.312 | 2.56 | 0.158 | 1.75 | — | 1.103 | 1.807 | 1.338 | 1.142 | |
| 1860 11410090 | -90 | 1 | 0.312 | 3.544 | 1.213 | 1.75 | 1.024 | 1.103 | 1.811 | 1.338 | 1.142 | |
| 1860 11410120 | -120 | 1 | 0.312 | 4.725 | 1.646 | 1.75 | 1.024 | 1.103 | 1.811 | 1.771 | 1.142 | |
| 1860 11412065 | CAT40 -PHC0375A -65 | 2 | 0.375 | 2.56 | 0.158 | 1.75 | — | 1.182 | 1.807 | 1.771 | 1.3 | |
| 1860 11412105 | -105 | 1 | 0.375 | 4.134 | 1.758 | 1.75 | 1.103 | 1.182 | 2.048 | 1.968 | 1.575 | |
| 1860 11412135 | -135 | 1 | 0.375 | 5.315 | 2.546 | 1.75 | 1.103 | 1.182 | 2.048 | 2.755 | 1.575 | |
| 1860 11416065 | CAT40 -PHC0500A -65 | 2 | 0.5 | 2.56 | 0.158 | 1.75 | — | 1.182 | 1.969 | 1.771 | 1.3 | |
| 1860 11416105 | -105 | 1 | 0.5 | 4.134 | 1.826 | 1.75 | 1.339 | 1.418 | 2.048 | 1.968 | 1.575 | |
| 1860 11416135 | -135 | 1 | 0.5 | 5.315 | 2.614 | 1.75 | 1.339 | 1.418 | 2.048 | 2.755 | 1.575 | |
| 1860 11420065 | CAT40 -PHC0625A -65 | 2 | 0.625 | 2.56 | 0.158 | 1.75 | — | 1.182 | 1.969 | 1.771 | 1.3 | |
| 1860 11420105 | -105 | 1 | 0.625 | 4.134 | 1.849 | 1.75 | 1.418 | 1.496 | 2.048 | 1.968 | 1.575 | |
| 1860 11420135 | -135 | 1 | 0.625 | 5.315 | 2.637 | 1.75 | 1.418 | 1.496 | 2.048 | 2.755 | 1.575 | |
| 1860 11424105 | CAT40 -PHC0750A -105 | 1 | 0.75 | 4.134 | 1.963 | 1.75 | 1.575 | 1.654 | 1.811 | 1.968 | 1.575 | |
| 1860 11424135 | -135 | 1 | 0.75 | 5.315 | 2.75 | 1.75 | 1.575 | 1.654 | 1.811 | 2.755 | 1.575 | |
| 1860 11432120 | CAT40 -PHC1000A -120 | 1 | 1 | 4.725 | 2.328 | 1.75 | 1.969 | 2.048 | 2.441 | 2.362 | 1.969 | L-6T (6mm) |
| 1860 11432150 | -150 | 1 | 1 | 5.906 | 3.115 | 1.75 | 1.969 | 2.048 | 2.441 | 3.149 | 1.969 | |
| 1860 11440135 | CAT40 -PHC1250A -135 | 1 | 1.25 | 5.315 | — | 1.75 | 2.363 | 2.441 | 2.441 | 2.952 | 2.56 | |
| 1860 11440165 | -165 | 1 | 1.25 | 6.496 | — | 1.75 | 2.363 | 2.441 | — | 3.149 | 2.56 | |

Inch Sizes Unit : Inch

| Code | Model | Type | d | L | L1 | D | D1 | D2 | D3 | ℓ | ℓ1 | wrench (Option) |
|------|----------------------|------|-------|-------|-------|------|-------|-------|-------|-------|-------|-----------------|
| — | CAT50 -PHC0250A -90 | 3 | 0.25 | 3.544 | 1.19 | 2.75 | 0.945 | 1.024 | 1.811 | 1.338 | 1.142 | L-4T (4mm) |
| — | -120 | 3 | 0.25 | 4.725 | 1.623 | 2.75 | 0.945 | 1.024 | 1.811 | 1.771 | 1.142 | |
| — | -150 | 3 | 0.25 | 5.906 | 1.623 | 2.75 | 0.945 | 1.024 | 1.811 | 1.771 | 1.142 | |
| — | CAT50 -PHC0312A -90 | 3 | 0.312 | 3.544 | 1.213 | 2.75 | 1.024 | 1.103 | 1.811 | 1.338 | 1.142 | |
| — | -120 | 3 | 0.312 | 4.725 | 1.646 | 2.75 | 1.024 | 1.103 | 1.811 | 1.771 | 1.142 | |
| — | -150 | 3 | 0.312 | 5.906 | 1.646 | 2.75 | 1.024 | 1.103 | 1.811 | 1.771 | 1.142 | |
| — | CAT50 -PHC0375A -105 | 3 | 0.375 | 4.134 | 1.758 | 2.75 | 1.103 | 1.182 | 2.048 | 1.968 | 1.575 | |
| — | -135 | 3 | 0.375 | 5.315 | 2.546 | 2.75 | 1.103 | 1.182 | 2.048 | 2.755 | 1.575 | |
| — | -165 | 3 | 0.375 | 6.496 | 2.546 | 2.75 | 1.103 | 1.182 | 2.048 | 2.755 | 1.575 | |
| — | CAT50 -PHC0500A -105 | 3 | 0.5 | 4.134 | 1.826 | 2.75 | 1.339 | 1.418 | 2.048 | 1.968 | 1.575 | |
| — | -135 | 3 | 0.5 | 5.315 | 2.614 | 2.75 | 1.339 | 1.418 | 2.048 | 2.755 | 1.575 | |
| — | -165 | 3 | 0.5 | 6.496 | 2.614 | 2.75 | 1.339 | 1.418 | 2.048 | 2.755 | 1.575 | |
| — | CAT50 -PHC0625A -105 | 3 | 0.625 | 4.134 | 1.849 | 2.75 | 1.418 | 1.496 | 2.048 | 1.968 | 1.575 | |
| — | -135 | 3 | 0.625 | 5.315 | 2.637 | 2.75 | 1.418 | 1.496 | 2.048 | 2.755 | 1.575 | |
| — | -165 | 3 | 0.625 | 6.496 | 2.637 | 2.75 | 1.418 | 1.496 | 2.048 | 2.755 | 1.575 | |
| — | CAT50 -PHC0750A -105 | 3 | 0.75 | 4.134 | 1.963 | 2.75 | 1.575 | 1.654 | 1.811 | 1.968 | 1.575 | |
| — | -135 | 3 | 0.75 | 5.315 | 2.75 | 2.75 | 1.575 | 1.654 | 1.811 | 2.755 | 1.575 | |
| — | -165 | 3 | 0.75 | 6.496 | 2.75 | 2.75 | 1.575 | 1.654 | 1.811 | 2.755 | 1.575 | |
| — | CAT50 -PHC1000A -120 | 3 | 1 | 4.725 | 2.328 | 2.75 | 1.969 | 2.048 | 2.441 | 2.362 | 1.969 | L-6T (6mm) |
| — | -150 | 3 | 1 | 5.906 | 3.115 | 2.75 | 1.969 | 2.048 | 2.441 | 3.149 | 1.969 | |
| — | -165 | 3 | 1 | 6.496 | 3.115 | 2.75 | 1.969 | 2.048 | 2.441 | 3.149 | 1.969 | |
| — | CAT50 -PHC1250A -135 | 3 | 1.25 | 5.315 | — | 2.75 | 2.363 | 2.441 | — | 2.952 | 2.56 | |
| — | -165 | 3 | 1.25 | 6.496 | — | 2.75 | 2.363 | 2.441 | — | 3.149 | 2.56 | |

- Cutting tool shank must be within tolerances specified below ;
 Shank diameter less than 6mm : Within h6 tolerance
 Shank diameter 6mm and over : Within h7 tolerance
 h6 or 0/-0.01 tolerance is recommended when newly making a cutting tool.
- Do not leave the holder with actuating screw tightened when the chuck is empty.
- PHC0500A and PHC0750A have pin holes for collet with stopper pin on its body.
- Hex-head screws (included) are necessary to plug air hole for center through coolant feed.
- For PHC04A, the stopper bolt is not included. Please order separately (Special item).
- For PHC04A, the length adjustment unit cannot be used.

| Tightening torque (Torque wrench : p.498) | | |
|---|-------------|------------------------|
| model | I.D. (d) | Tightening torque (Nm) |
| | inch | |
| PHC-A | 0250 ~ 0312 | 11 ~ 12 |
| PHC-A | 0375 ~ 0750 | 7 ~ 8 |
| PHC-A | 1000, 1250 | 29 ~ 30 |

Ordering Example
CAT40 - PHC 0250 A - 120
 Shank size I.D. (d) Projection length (L)

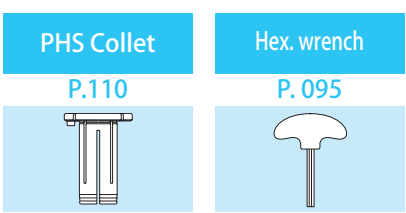

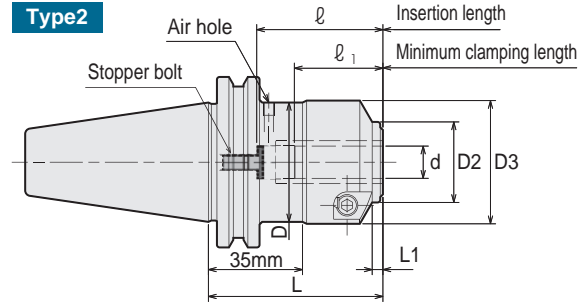
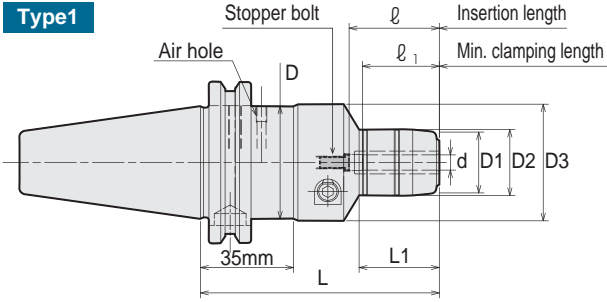

For PHC04A, the Stopper bolt is not included. Please order separately (Special item).

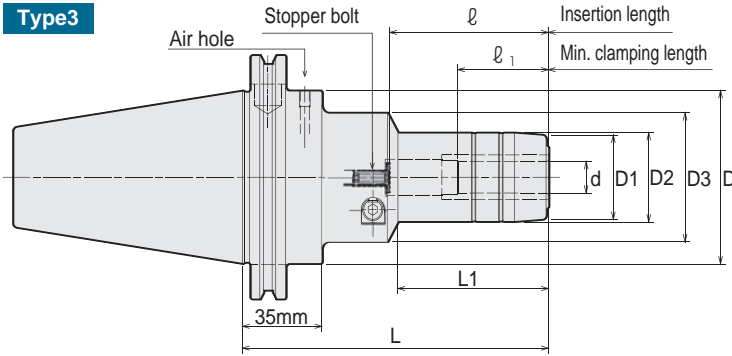

Metric Sizes

Unit : Inch

| Code | Model | Type | d | L | L1 | D | D1 | D2 | D3 | ℓ | ℓ1 | wrench (Option) |
|---------------|--------------------|------|----|-----|------|-------|----|----|-------|----|----|-----------------|
| 1860 01404080 | CAT40 -PHC04A -80 | 1 | 4 | 80 | 25.1 | — | 25 | 46 | — | 29 | 24 | L-4T (4mm) |
| 1860 01406065 | CAT40 -PHC06A -65 | 2 | 6 | 65 | 4 | — | — | 26 | 44.45 | 34 | 29 | |
| 1860 01406090 | -90 | 1 | 6 | 90 | 30 | 44.45 | 24 | 26 | 46 | 34 | 29 | |
| 1860 01406120 | -120 | 1 | 6 | 120 | 41 | 44.45 | 24 | 26 | 46 | 45 | 29 | |
| 1860 01407065 | CAT40 -PHC07A -65 | 2 | 7 | 65 | 4 | — | — | 28 | 44.45 | 34 | 29 | |
| 1860 01407090 | -90 | 1 | 7 | 90 | 30 | 44.45 | 26 | 28 | 46 | 34 | 29 | |
| 1860 01407120 | -120 | 1 | 7 | 120 | 41 | 44.45 | 26 | 28 | 46 | 45 | 29 | |
| 1860 01408065 | CAT40 -PHC08A -65 | 2 | 8 | 65 | 4 | — | — | 28 | 44.45 | 34 | 29 | |
| 1860 01408090 | -90 | 1 | 8 | 90 | 30 | 44.45 | 26 | 28 | 46 | 34 | 29 | |
| 1860 01408120 | -120 | 1 | 8 | 120 | 41 | 44.45 | 26 | 28 | 46 | 45 | 29 | |
| 1860 01409065 | CAT40 -PHC09A -65 | 2 | 9 | 65 | 4 | — | — | 30 | 44.45 | 45 | 33 | |
| 1860 01409105 | -105 | 1 | 9 | 105 | 44 | 44.45 | 28 | 30 | 52 | 50 | 40 | |
| 1860 01409135 | -135 | 1 | 9 | 135 | 64 | 44.45 | 28 | 30 | 52 | 70 | 40 | |
| 1860 01410065 | CAT40 -PHC10A -65 | 2 | 10 | 65 | 4 | — | — | 30 | 44.45 | 45 | 33 | |
| 1860 01410105 | -105 | 1 | 10 | 105 | 44 | 44.45 | 28 | 30 | 52 | 50 | 40 | |
| 1860 01410135 | -135 | 1 | 10 | 135 | 64 | 44.45 | 28 | 30 | 52 | 70 | 40 | |
| 1860 01411065 | CAT40 -PHC11A -65 | 2 | 11 | 65 | 4 | — | — | 30 | 44.45 | 45 | 33 | |
| 1860 01411105 | -105 | 1 | 11 | 105 | 45 | 44.45 | 30 | 32 | 52 | 50 | 40 | |
| 1860 01411135 | -135 | 1 | 11 | 135 | 65 | 44.45 | 30 | 32 | 52 | 70 | 40 | |
| 1860 01412065 | CAT40 -PHC12A -65 | 2 | 12 | 65 | 4 | — | — | 30 | 44.45 | 45 | 33 | |
| 1860 01412105 | -105 | 1 | 12 | 105 | 45 | 44.45 | 30 | 32 | 52 | 50 | 40 | |
| 1860 01412135 | -135 | 1 | 12 | 135 | 65 | 44.45 | 30 | 32 | 52 | 70 | 40 | |
| 1860 01413065 | CAT40 -PHC13A -65 | 3 | 13 | 65 | 4 | 44.45 | — | 30 | 50 | 45 | 33 | |
| 1860 01413105 | -105 | 1 | 13 | 105 | 46 | 44.45 | 34 | 36 | 52 | 50 | 40 | |
| 1860 01413135 | -135 | 1 | 13 | 135 | 66 | 44.45 | 34 | 36 | 52 | 70 | 40 | |
| 1860 01414065 | CAT40 -PHC14A -65 | 3 | 14 | 65 | 4 | 44.45 | — | 30 | 50 | 45 | 33 | |
| 1860 01414105 | -105 | 1 | 14 | 105 | 46 | 44.45 | 34 | 36 | 52 | 50 | 40 | |
| 1860 01414135 | -135 | 1 | 14 | 135 | 66 | 44.45 | 34 | 36 | 52 | 70 | 40 | |
| 1860 01415065 | CAT40 -PHC15A -65 | 3 | 15 | 65 | 4 | 44.45 | — | 30 | 50 | 45 | 33 | |
| 1860 01415105 | -105 | 1 | 15 | 105 | 46 | 44.45 | 36 | 38 | 52 | 50 | 40 | |
| 1860 01415135 | -135 | 1 | 15 | 135 | 66 | 44.45 | 36 | 38 | 52 | 70 | 40 | |
| 1860 01416065 | CAT40 -PHC16A -65 | 3 | 16 | 65 | 4 | 44.45 | — | 30 | 50 | 45 | 33 | |
| 1860 01416105 | -105 | 1 | 16 | 105 | 46 | 44.45 | 36 | 38 | 52 | 50 | 40 | |
| 1860 01416135 | -135 | 1 | 16 | 135 | 66 | 44.45 | 36 | 38 | 52 | 70 | 40 | |
| 1860 01420105 | CAT40 -PHC20A -105 | 1 | 20 | 105 | 49 | 44.45 | 40 | 42 | 46 | 50 | 40 | |
| 1860 01420135 | -135 | 1 | 20 | 135 | 69 | 44.45 | 40 | 42 | 46 | 70 | 40 | |
| 1860 01425120 | CAT40 -PHC25A -120 | 1 | 25 | 120 | 59 | 44.45 | 50 | 52 | 62 | 60 | 50 | |
| 1860 01425150 | -150 | 1 | 25 | 150 | 79 | 44.45 | 50 | 52 | 62 | 80 | 50 | |
| 1860 01432135 | CAT40 -PHC32A -135 | 1 | 32 | 135 | 100 | 44.45 | 60 | 62 | — | 75 | 65 | |
| 1860 01432165 | -165 | 1 | 32 | 165 | 130 | 44.45 | 60 | 62 | — | 80 | 65 | |

L-4T (4mm)

L-6T (6mm)

Metric Sizes

Unit : Inch

| Code | Model | Type | d | L | L1 | D | D1 | D2 | D3 | ℓ | ℓ1 | wrench (Option) |
|------|--------------------|------|----|-----|----|-------|----|----|----|----|----|-----------------|
| — | CAT50 -PHC06A -90 | 3 | 6 | 90 | 30 | 69.85 | 24 | 26 | 46 | 34 | 29 | L-4T (4mm) |
| — | -120 | 3 | 6 | 120 | 41 | 69.85 | 24 | 26 | 46 | 45 | 29 | |
| — | -150 | 3 | 6 | 150 | 41 | 69.85 | 24 | 26 | 46 | 45 | 29 | |
| — | CAT50 -PHC07A -90 | 3 | 7 | 90 | 30 | 69.85 | 26 | 28 | 46 | 34 | 29 | |
| — | -120 | 3 | 7 | 120 | 41 | 69.85 | 26 | 28 | 46 | 45 | 29 | |
| — | -150 | 3 | 7 | 150 | 41 | 69.85 | 26 | 28 | 46 | 45 | 29 | |
| — | CAT50 -PHC08A -90 | 3 | 8 | 90 | 30 | 69.85 | 26 | 28 | 46 | 34 | 29 | |
| — | -120 | 3 | 8 | 120 | 41 | 69.85 | 26 | 28 | 46 | 45 | 29 | |
| — | -150 | 3 | 8 | 150 | 41 | 69.85 | 26 | 28 | 46 | 45 | 29 | |
| — | CAT50 -PHC09A -105 | 3 | 9 | 105 | 44 | 69.85 | 28 | 30 | 52 | 50 | 40 | |
| — | -135 | 3 | 9 | 135 | 64 | 69.85 | 28 | 30 | 52 | 70 | 40 | |
| — | -165 | 3 | 9 | 165 | 64 | 69.85 | 28 | 30 | 52 | 70 | 40 | |
| — | CAT50 -PHC10A -105 | 3 | 10 | 105 | 44 | 69.85 | 28 | 30 | 52 | 50 | 40 | |
| — | -135 | 3 | 10 | 135 | 64 | 69.85 | 28 | 30 | 52 | 70 | 40 | |
| — | -165 | 3 | 10 | 165 | 64 | 69.85 | 28 | 30 | 52 | 70 | 40 | |
| — | CAT50 -PHC11A -105 | 3 | 11 | 105 | 45 | 69.85 | 30 | 32 | 52 | 50 | 40 | |
| — | -135 | 3 | 11 | 135 | 65 | 69.85 | 30 | 32 | 52 | 70 | 40 | |
| — | -165 | 3 | 11 | 165 | 65 | 69.85 | 30 | 32 | 52 | 70 | 40 | |
| — | CAT50 -PHC12A -105 | 3 | 12 | 105 | 45 | 69.85 | 30 | 32 | 52 | 50 | 40 | |
| — | -135 | 3 | 12 | 135 | 65 | 69.85 | 30 | 32 | 52 | 70 | 40 | |
| — | -165 | 3 | 12 | 165 | 65 | 69.85 | 30 | 32 | 52 | 70 | 40 | |
| — | CAT50 -PHC13A -105 | 3 | 13 | 105 | 46 | 69.85 | 34 | 36 | 52 | 50 | 40 | |
| — | -135 | 3 | 13 | 135 | 66 | 69.85 | 34 | 36 | 52 | 70 | 40 | |
| — | -165 | 3 | 13 | 165 | 66 | 69.85 | 34 | 36 | 52 | 70 | 40 | |
| — | CAT50 -PHC14A -105 | 3 | 14 | 105 | 46 | 69.85 | 34 | 36 | 52 | 50 | 40 | |
| — | -135 | 3 | 14 | 135 | 66 | 69.85 | 34 | 36 | 52 | 70 | 40 | |
| — | -165 | 3 | 14 | 165 | 66 | 69.85 | 34 | 36 | 52 | 70 | 40 | |
| — | CAT50 -PHC15A -105 | 3 | 15 | 105 | 46 | 69.85 | 36 | 38 | 52 | 50 | 40 | |
| — | -135 | 3 | 15 | 135 | 66 | 69.85 | 36 | 38 | 52 | 70 | 40 | |
| — | -165 | 3 | 15 | 165 | 66 | 69.85 | 36 | 38 | 52 | 70 | 40 | |
| — | CAT50 -PHC16A -105 | 3 | 16 | 105 | 46 | 69.85 | 36 | 38 | 52 | 50 | 40 | |
| — | -135 | 3 | 16 | 135 | 66 | 69.85 | 36 | 38 | 52 | 70 | 40 | |
| — | -165 | 3 | 16 | 165 | 66 | 69.85 | 36 | 38 | 52 | 70 | 40 | |
| — | CAT50 -PHC20A -105 | 3 | 20 | 105 | 49 | 69.85 | 40 | 42 | 46 | 50 | 40 | |
| — | -135 | 3 | 20 | 135 | 69 | 69.85 | 40 | 42 | 46 | 70 | 40 | |
| — | -165 | 3 | 20 | 165 | 69 | 69.85 | 40 | 42 | 46 | 70 | 40 | |
| — | CAT50 -PHC25A -120 | 3 | 25 | 120 | 59 | 69.85 | 50 | 52 | 62 | 64 | 50 | |
| — | -150 | 3 | 25 | 150 | 79 | 69.85 | 50 | 52 | 62 | 80 | 50 | |
| — | -165 | 3 | 25 | 165 | 79 | 69.85 | 50 | 52 | 62 | 80 | 50 | |
| — | CAT50 -PHC32A -135 | 3 | 32 | 135 | — | 69.85 | 60 | 62 | — | 75 | 65 | |
| — | -165 | 3 | 32 | 165 | — | 69.85 | 60 | 62 | — | 80 | 65 | |

1. Cutting tool shank must be within tolerances specified below ;
Shank diameter less than 6mm : Within h6 tolerance
Shank diameter 6mm and over : Within h7 tolerance
h6 or 0/-0.01 tolerance is recommended when newly making a cutting tool.
2. Do not leave the holder with actuating screw tightened when the chuck is empty.
3. PHC12A and PHC20A have pin holes for collet with stopper pin on its body.
4. Hex-head screws (included) are necessary to plug air hole for center through coolant feed.
5. For PHC04A, the stopper bolt is not included. Please order separately (Special item).
6. For PHC04A, the length adjustment unit cannot be used.

| Tightening torque (Torque wrench : p.498) | | |
|---|----------------|---------------------------|
| model | I.D. (d) mm | Tightening torque (Nm) |
| PHC-A | 06 ~ 08 | 11 ~ 12 |
| PHC-A | 09 ~ 20 | 7 ~ 8 |
| PHC-A | 25, 32 | 29 ~ 30 |

Ordering Example

CAT40 - PHC 12 A - 135
 Shank size I.D. (d) Projection length (L)

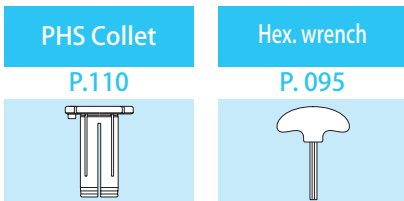

Length adjustment unit

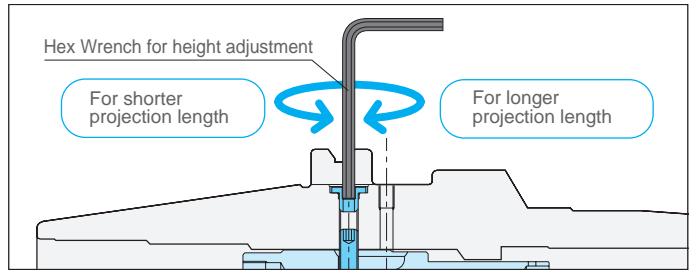
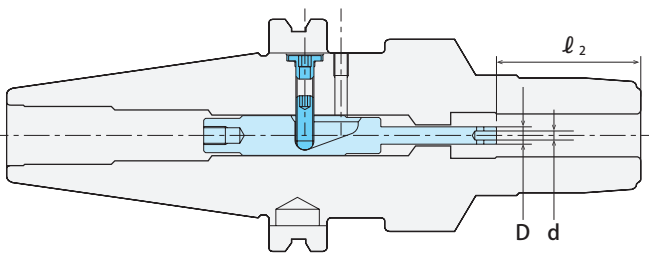

Inch Sizes

Unit : Metric

| Code | Length adjustment unit | Matched chuck | Adjustment range l_2 | Adjustable amount | Pin end I.D. d | Pin end O.D. D |
|---------------|------------------------|----------------------|------------------------|-------------------|----------------|----------------|
| 3934 24045423 | PHC-P404-5423 | CAT40 -PHC0250A -90 | 29-34 | 5 | 2 | 3.8 |
| 3934 24047334 | PHC-P404-7334 | -120 | 29-39 | 10 | 2 | 3.8 |
| 3934 24047328 | PHC-P404-7328 | -120 | 35-45 | 10 | 2 | 3.8 |
| 3934 24045423 | PHC-P404-5423 | CAT40 -PHC0312A -90 | 29-34 | 5 | 2 | 3.8 |
| 3934 24047334 | PHC-P404-7334 | -120 | 29-39 | 10 | 2 | 3.8 |
| 3934 24047328 | PHC-P404-7328 | -120 | 35-45 | 10 | 2 | 3.8 |
| 3934 24054932 | PHC-P405-4932 | CAT40 -PHC0375A -105 | 40-50 | 10 | 2.5 | 4.8 |
| 3934 24055952 | PHC-P405-5952 | -135 | 40-50 | 10 | 2.5 | 4.8 |
| 3934 24054952 | PHC-P405-4952 | -135 | 50-60 | 10 | 2.5 | 4.8 |
| 3934 24054942 | PHC-P405-4942 | -135 | 60-70 | 10 | 2.5 | 4.8 |
| 3934 24054932 | PHC-P405-4932 | CAT40 -PHC0500A -105 | 40-50 | 10 | 2.5 | 4.8 |
| 3934 24055952 | PHC-P405-5952 | -135 | 40-50 | 10 | 2.5 | 4.8 |
| 3934 24054952 | PHC-P405-4952 | -135 | 50-60 | 10 | 2.5 | 4.8 |
| 3934 24054942 | PHC-P405-4942 | -135 | 60-70 | 10 | 2.5 | 4.8 |
| 3934 24054932 | PHC-P405-4932 | CAT40 -PHC0625A -105 | 40-50 | 10 | 2.5 | 4.8 |
| 3934 24055952 | PHC-P405-5952 | -135 | 40-50 | 10 | 2.5 | 4.8 |
| 3934 24054952 | PHC-P405-4952 | -135 | 50-60 | 10 | 2.5 | 4.8 |
| 3934 24054942 | PHC-P405-4942 | -135 | 60-70 | 10 | 2.5 | 4.8 |
| 3934 24054932 | PHC-P405-4932 | CAT40 -PHC0750A -105 | 40-50 | 10 | 2.5 | 4.8 |
| 3934 24055952 | PHC-P405-5952 | -135 | 40-50 | 10 | 2.5 | 4.8 |
| 3934 24054952 | PHC-P405-4952 | -135 | 50-60 | 10 | 2.5 | 4.8 |
| 3934 24054942 | PHC-P405-4942 | -135 | 60-70 | 10 | 2.5 | 4.8 |
| 3934 24055432 | PHC-P405-5432 | CAT40 -PHC1000A -120 | 50-60 | 10 | 2.5 | 4.8 |
| 3934 24056452 | PHC-P405-6452 | -150 | 50-60 | 10 | 2.5 | 4.8 |
| 3934 24055452 | PHC-P405-5452 | -150 | 60-70 | 10 | 2.5 | 4.8 |
| 3934 24055442 | PHC-P405-5442 | -150 | 70-80 | 10 | 2.5 | 4.8 |
| 3934 24055432 | PHC-P405-5432 | CAT40 -PHC1250A -135 | 65-75 | 10 | 2.5 | 4.8 |
| 3934 24056452 | PHC-P405-6452 | -165 | 65-75 | 10 | 2.5 | 4.8 |
| 3934 24055952 | PHC-P405-5952 | -165 | 70-80 | 10 | 2.5 | 4.8 |

Length adjustment unit can be used for chucks other than 45mm projection length.
 Length adjustment unit can be used with BT, CAT and SK shank chucks only.
 For PHC04A, the length adjustment unit cannot be used.

Ordering Example

CAT40-PHC10A-105 with adjustment range of 40-50mm
 (Adjustable amount-10mm).

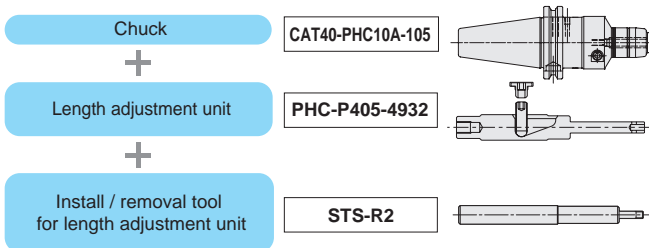

| Shank size | Hex wrench size for height adjustment | Install / removal tool for length adjustment unit |
|------------|---------------------------------------|---|
| CAT40 | 2.5mm | STS-R2 |

Metric Sizes

Unit : Metric

| Code | Length adjustment unit | Adjustment range ± 2 | Matched chuck | Adjustable amount | Pin end I.D. d | Pin end O.D. D |
|---------------|------------------------|--------------------------|--------------------|-------------------|----------------|----------------|
| 3934 24045423 | PHC-P404-5423 | 29-34 | CAT40 -PHC06A -90 | 5 | 2 | 3.8 |
| 3934 24047334 | PHC-P404-7334 | 29-39 | -120 | 10 | 2 | 3.8 |
| 3934 24047328 | PHC-P404-7328 | 35-45 | -120 | 10 | 2 | 3.8 |
| 3934 24045423 | PHC-P404-5423 | 29-34 | CAT40 -PHC07A -90 | 5 | 2 | 3.8 |
| 3934 24047334 | PHC-P404-7334 | 29-39 | -120 | 10 | 2 | 3.8 |
| 3934 24047328 | PHC-P404-7328 | 35-45 | -120 | 10 | 2 | 3.8 |
| 3934 24045423 | PHC-P404-5423 | 29-34 | CAT40 -PHC08A -90 | 5 | 2 | 3.8 |
| 3934 24047334 | PHC-P404-7334 | 29-39 | -120 | 10 | 2 | 3.8 |
| 3934 24047328 | PHC-P404-7328 | 35-45 | -120 | 10 | 2 | 3.8 |
| 3934 24054932 | PHC-P405-4932 | 40-50 | CAT40 -PHC09A -105 | 10 | 2.5 | 4.8 |
| 3934 24055952 | PHC-P405-5952 | 40-50 | -135 | 10 | 2.5 | 4.8 |
| 3934 24054952 | PHC-P405-4952 | 50-60 | -135 | 10 | 2.5 | 4.8 |
| 3934 24054942 | PHC-P405-4942 | 60-70 | -135 | 10 | 2.5 | 4.8 |
| 3934 24054932 | PHC-P405-4932 | 40-50 | CAT40 -PHC10A -105 | 10 | 2.5 | 4.8 |
| 3934 24055952 | PHC-P405-5952 | 40-50 | -135 | 10 | 2.5 | 4.8 |
| 3934 24054952 | PHC-P405-4952 | 50-60 | -135 | 10 | 2.5 | 4.8 |
| 3934 24054942 | PHC-P405-4942 | 60-70 | -135 | 10 | 2.5 | 4.8 |
| 3934 24054932 | PHC-P405-4932 | 40-50 | CAT40 -PHC11A -105 | 10 | 2.5 | 4.8 |
| 3934 24055952 | PHC-P405-5952 | 40-50 | -135 | 10 | 2.5 | 4.8 |
| 3934 24054952 | PHC-P405-4952 | 50-60 | -135 | 10 | 2.5 | 4.8 |
| 3934 24054942 | PHC-P405-4942 | 60-70 | -135 | 10 | 2.5 | 4.8 |
| 3934 24054932 | PHC-P405-4932 | 40-50 | CAT40 -PHC12A -105 | 10 | 2.5 | 4.8 |
| 3934 24055952 | PHC-P405-5952 | 40-50 | -135 | 10 | 2.5 | 4.8 |
| 3934 24054952 | PHC-P405-4952 | 50-60 | -135 | 10 | 2.5 | 4.8 |
| 3934 24054942 | PHC-P405-4942 | 60-70 | -135 | 10 | 2.5 | 4.8 |
| 3934 24054932 | PHC-P405-4932 | 40-50 | CAT40 -PHC13A -105 | 10 | 2.5 | 4.8 |
| 3934 24055952 | PHC-P405-5952 | 40-50 | -135 | 10 | 2.5 | 4.8 |
| 3934 24054952 | PHC-P405-4952 | 50-60 | -135 | 10 | 2.5 | 4.8 |
| 3934 24054942 | PHC-P405-4942 | 60-70 | -135 | 10 | 2.5 | 4.8 |
| 3934 24054932 | PHC-P405-4932 | 40-50 | CAT40 -PHC14A -105 | 10 | 2.5 | 4.8 |
| 3934 24055952 | PHC-P405-5952 | 40-50 | -135 | 10 | 2.5 | 4.8 |
| 3934 24054952 | PHC-P405-4952 | 50-60 | -135 | 10 | 2.5 | 4.8 |
| 3934 24054942 | PHC-P405-4942 | 60-70 | -135 | 10 | 2.5 | 4.8 |
| 3934 24054932 | PHC-P405-4932 | 40-50 | CAT40 -PHC15A -105 | 10 | 2.5 | 4.8 |
| 3934 24055952 | PHC-P405-5952 | 40-50 | -135 | 10 | 2.5 | 4.8 |
| 3934 24054952 | PHC-P405-4952 | 50-60 | -135 | 10 | 2.5 | 4.8 |
| 3934 24054942 | PHC-P405-4942 | 60-70 | -135 | 10 | 2.5 | 4.8 |
| 3934 24054932 | PHC-P405-4932 | 40-50 | CAT40 -PHC16A -105 | 10 | 2.5 | 4.8 |
| 3934 24055952 | PHC-P405-5952 | 40-50 | -135 | 10 | 2.5 | 4.8 |
| 3934 24054952 | PHC-P405-4952 | 50-60 | -135 | 10 | 2.5 | 4.8 |
| 3934 24054942 | PHC-P405-4942 | 60-70 | -135 | 10 | 2.5 | 4.8 |
| 3934 24054932 | PHC-P405-4932 | 40-50 | CAT40 -PHC20A -105 | 10 | 2.5 | 4.8 |
| 3934 24055952 | PHC-P405-5952 | 40-50 | -135 | 10 | 2.5 | 4.8 |
| 3934 24054952 | PHC-P405-4952 | 50-60 | -135 | 10 | 2.5 | 4.8 |
| 3934 24054942 | PHC-P405-4942 | 60-70 | -135 | 10 | 2.5 | 4.8 |
| 3934 24055432 | PHC-P405-5432 | 50-60 | CAT40 -PHC25A -120 | 10 | 2.5 | 4.8 |
| 3934 24056452 | PHC-P405-6452 | 50-60 | -150 | 10 | 2.5 | 4.8 |
| 3934 24055452 | PHC-P405-5452 | 60-70 | -150 | 10 | 2.5 | 4.8 |
| 3934 24055442 | PHC-P405-5442 | 70-80 | -150 | 10 | 2.5 | 4.8 |
| 3934 24055432 | PHC-P405-5432 | 65-75 | CAT40 -PHC32A -135 | 10 | 2.5 | 4.8 |
| 3934 24056452 | PHC-P405-6452 | 65-75 | -165 | 10 | 2.5 | 4.8 |
| 3934 24055952 | PHC-P405-5952 | 70-80 | -165 | 10 | 2.5 | 4.8 |

Length adjustment unit can be used for chucks other than 45mm projection length.

Length adjustment unit can be used with BT, CAT and SK shank chucks only.

For PHC04A, the length adjustment unit cannot be used.

Metric Sizes

Unit : Metric

| Code | Model | Type | d | L | L1 | D1 | D2 | D3 | L0 | ℓ | ℓ1 | Wrench (Option) | |
|--------------|-----------------|------|---|----|-----|-----|----|----|----|----|----|-----------------|---------------|
| 573015225135 | HSK63A -PHC25A | -135 | 2 | 25 | 135 | 59 | 50 | 52 | 59 | 42 | 60 | 50 | L-6T (6mm) |
| 573015225150 | | -150 | 2 | 25 | 150 | 79 | 50 | 52 | 59 | 42 | 80 | 50 | |
| 573015232135 | HSK63A -PHC32A | -135 | 2 | 32 | 135 | 42 | 60 | 62 | 85 | 42 | 80 | 65 | |
| 573015232150 | | -150 | 2 | 32 | 150 | 108 | 60 | 62 | 62 | 42 | 80 | 65 | |
| 573017206090 | HSK100A -PHC06A | -90 | 1 | 6 | 90 | 30 | 24 | 26 | 46 | — | 34 | 29 | L-4T (4mm) |
| 573017206120 | | -120 | 1 | 6 | 120 | 41 | 24 | 26 | 46 | — | 45 | 29 | |
| 573017206150 | | -150 | 1 | 6 | 150 | 41 | 24 | 26 | 46 | — | 45 | 29 | |
| 573017207090 | HSK100A -PHC07A | -90 | 1 | 7 | 90 | 30 | 26 | 28 | 46 | — | 34 | 29 | |
| 573017207120 | | -120 | 1 | 7 | 120 | 41 | 26 | 28 | 46 | — | 45 | 29 | |
| 573017207150 | | -150 | 1 | 7 | 150 | 41 | 26 | 28 | 46 | — | 45 | 29 | |
| 573017208090 | HSK100A -PHC08A | -90 | 1 | 8 | 90 | 30 | 26 | 28 | 46 | — | 34 | 29 | |
| 573017208120 | | -120 | 1 | 8 | 120 | 41 | 26 | 28 | 46 | — | 45 | 29 | |
| 573017208150 | | -150 | 1 | 8 | 150 | 41 | 26 | 28 | 46 | — | 45 | 29 | |
| 573017209105 | HSK100A -PHC09A | -105 | 1 | 9 | 105 | 44 | 28 | 30 | 52 | — | 50 | 40 | |
| 573017209135 | | -135 | 1 | 9 | 135 | 64 | 28 | 30 | 52 | — | 70 | 40 | |
| 573017209165 | | -165 | 1 | 9 | 165 | 64 | 28 | 30 | 52 | — | 70 | 40 | |
| 573017210105 | HSK100A -PHC10A | -105 | 1 | 10 | 105 | 44 | 28 | 30 | 52 | — | 50 | 40 | |
| 573017210135 | | -135 | 1 | 10 | 135 | 64 | 28 | 30 | 52 | — | 70 | 40 | |
| 573017210165 | | -165 | 1 | 10 | 165 | 64 | 28 | 30 | 52 | — | 70 | 40 | |
| 573017211105 | HSK100A -PHC11A | -105 | 1 | 11 | 105 | 45 | 30 | 32 | 52 | — | 50 | 40 | |
| 573017211135 | | -135 | 1 | 11 | 135 | 65 | 30 | 32 | 52 | — | 70 | 40 | |
| 573017211165 | | -165 | 1 | 11 | 165 | 65 | 30 | 32 | 52 | — | 70 | 40 | |
| 573017212105 | HSK100A -PHC12A | -105 | 1 | 12 | 105 | 45 | 30 | 32 | 52 | — | 50 | 40 | |
| 573017212135 | | -135 | 1 | 12 | 135 | 65 | 30 | 32 | 52 | — | 70 | 40 | |
| 573017212165 | | -165 | 1 | 12 | 165 | 65 | 30 | 32 | 52 | — | 70 | 40 | |
| 573017213105 | HSK100A -PHC13A | -105 | 1 | 13 | 105 | 46 | 34 | 36 | 52 | — | 50 | 40 | |
| 573017213135 | | -135 | 1 | 13 | 135 | 66 | 34 | 36 | 52 | — | 70 | 40 | |
| 573017213165 | | -165 | 1 | 13 | 165 | 66 | 34 | 36 | 52 | — | 70 | 40 | |
| 573017214105 | HSK100A -PHC14A | -105 | 1 | 14 | 105 | 46 | 34 | 36 | 52 | — | 50 | 40 | |
| 573017214135 | | -135 | 1 | 14 | 135 | 66 | 34 | 36 | 52 | — | 70 | 40 | |
| 573017214165 | | -165 | 1 | 14 | 165 | 66 | 34 | 36 | 52 | — | 70 | 40 | |
| 573017215105 | HSK100A -PHC15A | -105 | 1 | 15 | 105 | 46 | 36 | 38 | 52 | — | 50 | 40 | |
| 573017215135 | | -135 | 1 | 15 | 135 | 66 | 36 | 38 | 52 | — | 70 | 40 | |
| 573017215165 | | -165 | 1 | 15 | 165 | 66 | 36 | 38 | 52 | — | 70 | 40 | |
| 573017216105 | HSK100A -PHC16A | -105 | 1 | 16 | 105 | 46 | 36 | 38 | 52 | — | 50 | 40 | |
| 573017216135 | | -135 | 1 | 16 | 135 | 66 | 36 | 38 | 52 | — | 70 | 40 | |
| 573017216165 | | -165 | 1 | 16 | 165 | 66 | 36 | 38 | 52 | — | 70 | 40 | |
| 573017220105 | HSK100A -PHC20A | -105 | 1 | 20 | 105 | 49 | 40 | 42 | 46 | — | 50 | 40 | |
| 573017220135 | | -135 | 1 | 20 | 135 | 69 | 40 | 42 | 46 | — | 70 | 40 | |
| 573017220165 | | -165 | 1 | 20 | 165 | 69 | 40 | 42 | 46 | — | 70 | 40 | |
| 573017225120 | HSK100A -PHC25A | -120 | 1 | 25 | 120 | 59 | 50 | 52 | 62 | — | 64 | 50 | |
| 573017225165 | | -165 | 1 | 25 | 165 | 79 | 50 | 52 | 62 | — | 80 | 50 | |
| 573017232135 | HSK100A -PHC32A | -135 | 3 | 32 | 135 | — | 60 | 62 | — | — | 80 | 65 | L-6T (6mm) |
| 573017232165 | | -165 | 3 | 32 | 165 | — | 60 | 62 | — | — | 80 | 65 | |

- Cutting tool shank must be within tolerances specified below ;
Shank diameter less than 6mm : Within h6 tolerance
Shank diameter 6mm and over : Within h7 tolerance
h6 or 0/-0.01 tolerance is recommended when newly making a cutting tool.
- Do not leave the holder with actuating screw tightened when the chuck is empty.
- PHC12A and PHC20A have pin holes for collet with stopper pin on its body.

Ordering Example

HSK100A - PHC 06 A - 90
 Shank size I.D. (d) Projection length (L)

| Tightening torque (Torque wrench : p.498) | | | |
|---|----------|-------------|------------------------|
| model | I.D. (d) | | Tightening torque (Nm) |
| | mm | inch | |
| PHC-A | 06 ~ 08 | 0250 ~ 0312 | 11 ~ 12 |
| PHC-A | 09 ~ 20 | 0375 ~ 0750 | 7 ~ 8 |
| PHC-A | 25, 32 | 1000, 1250 | 29 ~ 30 |

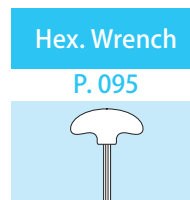
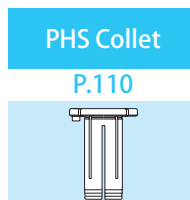

PHC-A

Power Hydro Chuck

- Hydro chuck with collet holder flexibility. Suitable for high precision cutting.

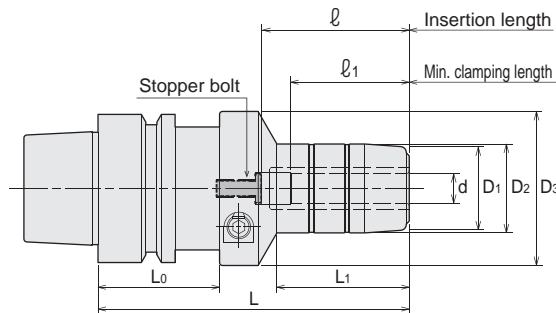

Metric Sizes

Unit : Metric

| Code | Model | d | L | L1 | D1 | D2 | D3 | L0 | l | l1 | Kg | Wrench (Option) |
|---------------|---------------------------|----|-----|----|----|----|----|----|----|----|-----|-----------------|
| 5730 53206090 | HSK40E -PHC06A-90 | 6 | 90 | 30 | 24 | 26 | 46 | 35 | 34 | 29 | 0.7 | L-4T (4mm) |
| 5730 53207090 | HSK40E -PHC07A-90 | 7 | 90 | 30 | 26 | 28 | 46 | 35 | 34 | 29 | | |
| 5730 53208090 | HSK40E -PHC08A-90 | 8 | 90 | 30 | 26 | 28 | 46 | 35 | 34 | 29 | | |
| 5730 53209105 | HSK40E -PHC09A-105 | 9 | 105 | 44 | 28 | 30 | 52 | 35 | 50 | 40 | | |
| 5730 53210105 | HSK40E -PHC10A-105 | 10 | 105 | 44 | 28 | 30 | 52 | 35 | 50 | 40 | | |
| 5730 53211105 | HSK40E -PHC11A-105 | 11 | 105 | 45 | 30 | 32 | 52 | 35 | 50 | 40 | | |
| 5730 53212105 | HSK40E -PHC12A-105 | 12 | 105 | 45 | 30 | 32 | 52 | 35 | 50 | 40 | | L-4T (4mm) |
| 5730 54206090 | HSK50E -PHC06A-90 | 6 | 90 | 30 | 24 | 26 | 46 | 41 | 34 | 29 | 0.9 | |
| 5730 54207090 | HSK50E -PHC07A-90 | 7 | 90 | 30 | 26 | 28 | 46 | 41 | 34 | 29 | | |
| 5730 54208090 | HSK50E -PHC08A-90 | 8 | 90 | 30 | 26 | 28 | 46 | 41 | 34 | 29 | | |
| 5730 54209105 | HSK50E -PHC09A-105 | 9 | 105 | 44 | 28 | 30 | 52 | 41 | 50 | 40 | | |
| 5730 54210105 | HSK50E -PHC10A-105 | 10 | 105 | 44 | 28 | 30 | 52 | 41 | 50 | 40 | | |
| 5730 54211105 | HSK50E -PHC11A-105 | 11 | 105 | 45 | 30 | 32 | 52 | 41 | 50 | 40 | | |
| 5730 54212105 | HSK50E -PHC12A-105 | 12 | 105 | 45 | 30 | 32 | 52 | 41 | 50 | 40 | | |
| 5730 54213105 | HSK50E -PHC13A-105 | 13 | 105 | 46 | 34 | 36 | 52 | 41 | 50 | 40 | | |
| 5730 54214105 | HSK50E -PHC14A-105 | 14 | 105 | 46 | 34 | 36 | 52 | 41 | 50 | 40 | | |
| 5730 54215105 | HSK50E -PHC15A-105 | 15 | 105 | 46 | 36 | 38 | 52 | 41 | 50 | 40 | | |
| 5730 54216105 | HSK50E -PHC16A-105 | 16 | 105 | 46 | 36 | 38 | 52 | 41 | 50 | 40 | | |
| 5730 54220105 | HSK50E -PHC20A-105 | 20 | 105 | 49 | 40 | 42 | 46 | 41 | 50 | 40 | | |

1. Please use a cutting tool with a tolerance of less than h7. A tolerance of less than 0/-001 is recommended for new cutting tools.

2. Do not leave the holder with actuating screw tightened when the chuck is empty.

3. PHC12A and PHC20A have pin holes for collet with stopper pin on its body.

Ordering Example

HSK50E - PHC 12 A - 105

Shank size

I.D. (d)

Projection length (L)

| Tightening torque (Torque wrench : p.498) | | |
|---|----------------|---------------------------|
| model | I.D. (d) mm | Tightening torque (Nm) |
| PHC-A | 06 ~ 08 | 11 ~ 12 |
| PHC-A | 09 ~ 20 | 7 ~ 8 |
| PHC-A | 25, 32 | 29 ~ 30 |

PHS Collet

P.110

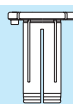

Hex. Wrench

P. 095



PHC-A

Power Hydro Chuck

- Hydro chuck with collet holder flexibility. Suitable for high precision cutting.

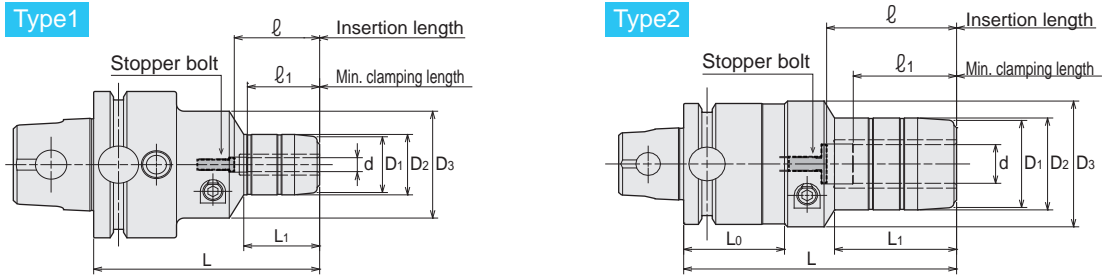

For PHC04A, the stopper bolt is not included. Please order separately (Special item).

Metric Sizes

Unit : Metric

| Code | Model | Type | d | L | L1 | D1 | D2 | D3 | L0 | l | l1 | Kg | Wrench (Option) |
|---------------|------------------------|------|----|-----|------|----|----|----|----|----|----|-----|-----------------|
| 1390 11104075 | UTS5040 -PHC04A -75-H | 1 | 4 | 75 | 25.1 | — | 25 | 46 | — | 29 | 24 | | L-4T |
| 1390 11106090 | UTS5040 -PHC06A -90-H | 1 | 6 | 90 | 30 | 24 | 26 | 46 | — | 34 | 29 | 1.0 | |
| 1390 11107090 | UTS5040 -PHC07A -90-H | 1 | 7 | 90 | 30 | 26 | 28 | 46 | — | 34 | 29 | 1.0 | |
| 1390 11108090 | UTS5040 -PHC08A -90-H | 1 | 8 | 90 | 30 | 26 | 28 | 46 | — | 34 | 29 | 1.0 | |
| 1390 11109105 | UTS5040 -PHC09A -105-H | 2 | 9 | 105 | 44 | 28 | 30 | 52 | 38 | 50 | 40 | 1.1 | |
| 1390 11110105 | UTS5040 -PHC10A -105-H | 2 | 10 | 105 | 44 | 28 | 30 | 52 | 38 | 50 | 40 | 1.1 | |
| 1390 11111105 | UTS5040 -PHC11A -105-H | 2 | 11 | 105 | 45 | 30 | 32 | 52 | 38 | 50 | 40 | 1.1 | |
| 1390 11112105 | UTS5040 -PHC12A -105-H | 2 | 12 | 105 | 45 | 30 | 32 | 52 | 38 | 50 | 40 | 1.1 | |
| 1390 11113105 | UTS5040 -PHC13A -105-H | 2 | 13 | 105 | 46 | 34 | 36 | 52 | 38 | 50 | 40 | 1.2 | |
| 1390 11114105 | UTS5040 -PHC14A -105-H | 2 | 14 | 105 | 46 | 34 | 36 | 52 | 38 | 50 | 40 | 1.2 | |
| 1390 11115105 | UTS5040 -PHC15A -105-H | 2 | 15 | 105 | 46 | 36 | 38 | 52 | 38 | 50 | 40 | 1.2 | |
| 1390 11116105 | UTS5040 -PHC16A -105-H | 2 | 16 | 105 | 46 | 36 | 38 | 52 | 38 | 50 | 40 | 1.2 | |
| 1390 1120105 | UTS5040 -PHC20A -105-H | 1 | 20 | 105 | 49 | 40 | 42 | 46 | — | 50 | 40 | 1.2 | |
| 1390 1※204080 | UTS6350 -PHC04A -80 | 1 | 4 | 80 | 25.1 | — | 25 | 46 | — | 29 | 24 | | |
| 1390 1※206090 | UTS6350 -PHC06A -90 | 1 | 6 | 90 | 30 | 24 | 26 | 46 | — | 34 | 29 | 1.3 | |
| 1390 1※207090 | UTS6350 -PHC07A -90 | 1 | 7 | 90 | 30 | 26 | 28 | 46 | — | 34 | 29 | | |
| 1390 1※208090 | UTS6350 -PHC08A -90 | 1 | 8 | 90 | 30 | 26 | 28 | 46 | — | 34 | 29 | | |
| 1390 1※209105 | UTS6350 -PHC09A -105 | 1 | 9 | 105 | 44 | 28 | 30 | 52 | — | 50 | 40 | 1.5 | |
| 1390 1※210105 | UTS6350 -PHC10A -105 | 1 | 10 | 105 | 44 | 28 | 30 | 52 | — | 50 | 40 | 1.5 | |
| 1390 1※211105 | UTS6350 -PHC11A -105 | 1 | 11 | 105 | 45 | 30 | 32 | 52 | — | 50 | 40 | | |
| 1390 1※212105 | UTS6350 -PHC12A -105 | 1 | 12 | 105 | 45 | 30 | 32 | 52 | — | 50 | 40 | 1.5 | |
| 1390 1※213105 | UTS6350 -PHC13A -105 | 1 | 13 | 105 | 46 | 34 | 36 | 52 | — | 50 | 40 | | |
| 1390 1※214105 | UTS6350 -PHC14A -105 | 1 | 14 | 105 | 46 | 34 | 36 | 52 | — | 50 | 40 | 1.5 | |
| 1390 1※215105 | UTS6350 -PHC15A -105 | 1 | 15 | 105 | 46 | 36 | 38 | 52 | — | 50 | 40 | | |
| 1390 1※216105 | UTS6350 -PHC16A -105 | 1 | 16 | 105 | 46 | 36 | 38 | 52 | — | 50 | 40 | 1.6 | |
| 1390 1※220105 | UTS6350 -PHC20A -105 | 1 | 20 | 105 | 49 | 40 | 42 | 46 | — | 50 | 40 | 1.5 | |
| 1390 1※225120 | UTS6350 -PHC25A -120 | 1 | 25 | 120 | 59 | 50 | 52 | 59 | — | 60 | 50 | 2.1 | L-6T |

When placing an order, please specify high or low pressure.
For high pressure type, please add (-H) on end of the description.

- Cutting tool shank must be within tolerances specified below ;
Shank diameter less than 6mm : Within h6 tolerance
Shank diameter 6mm and over : Within h7 tolerance
h6 or 0/-0.01 tolerance is recommended when newly making a cutting tool.
- Do not leave the holder with actuating screw tightened when the chuck is empty.
- PHC12A and PHC20A have pin holes for collet with stopper pin on its body.
- UTS5040 is available in high pressure only.
- For PHC04A, the stopper bolt is not included. Please order separately (Special item).

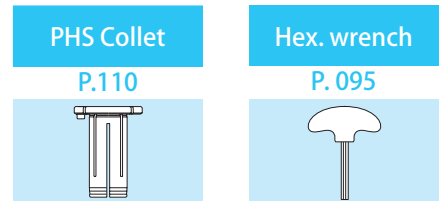

| Tightening torque (Torque wrench : p.498) | | |
|---|----------------|---------------------------|
| model | I.D. (d) mm | Tightening torque (Nm) |
| PHC-A | 06 ~ 08 | 11 ~ 12 |
| PHC-A | 09 ~ 20 | 7 ~ 8 |
| PHC-A | 25, 32 | 29 ~ 30 |

Ordering Example

Low pressure type

0 ~ 1.0MPa (UTS10080 : 0 ~ 2.0MPa)

UTS6350 - PHC 12 A - 105
Shank size I.D. (d) Projection length (L)

Ordering Example

High pressure type

1.1 ~ 7.0MPa (UTS10080 : 2.1 ~ 7.0MPa)

UTS6350 - PHC 12 A - 105 - H
Shank size I.D. (d) Projection length (L) High pressure type

PHC-A

Power Hydro Chuck

- Hydro chuck with collet holder flexibility. Suitable for high precision cutting.

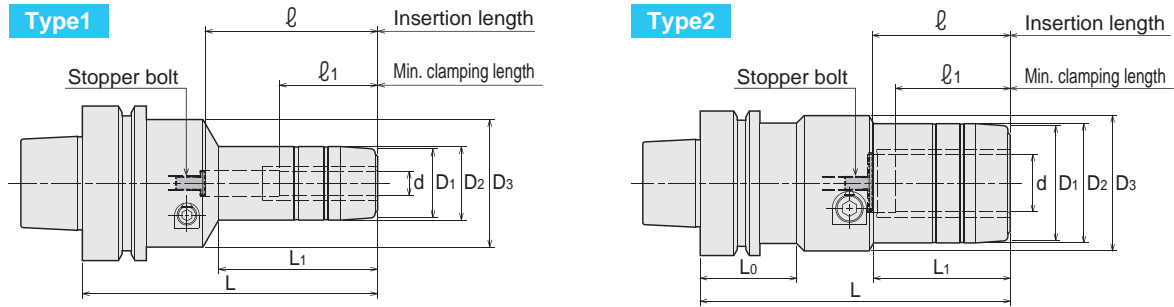

Metric Sizes

Unit : Metric

| Code | Model | Type | d | L | L1 | D1 | D2 | D3 | L0 | l | l1 | Kg | Wrench (Option) |
|---------------|---------------------------|------|----|-----|-----|----|----|----|----|----|----|-----|-----------------|
| 5730 65206075 | HSK63F -PHC06A-75 | 1 | 6 | 75 | 30 | 24 | 26 | 46 | — | 34 | 29 | 1.0 | L-4T (4mm) |
| 5730 65206120 | -120 | 1 | 6 | 120 | 41 | 24 | 26 | 46 | — | 45 | 29 | | |
| 5730 65207075 | HSK63F -PHC07A-75 | 1 | 7 | 75 | 30 | 26 | 28 | 46 | — | 34 | 29 | | |
| 5730 65207120 | -120 | 1 | 7 | 120 | 41 | 26 | 28 | 46 | — | 45 | 29 | | |
| 5730 65208075 | HSK63F -PHC08A-75 | 1 | 8 | 75 | 30 | 26 | 28 | 46 | — | 34 | 29 | | |
| 5730 65208120 | -120 | 1 | 8 | 120 | 41 | 26 | 28 | 46 | — | 45 | 29 | | |
| 5730 65209090 | HSK63F -PHC09A-90 | 1 | 9 | 90 | 44 | 28 | 30 | 52 | — | 50 | 40 | | |
| 5730 65209120 | -120 | 1 | 9 | 120 | 64 | 28 | 30 | 52 | — | 70 | 40 | | |
| 5730 65210090 | HSK63F -PHC10A-90 | 1 | 10 | 90 | 44 | 28 | 30 | 52 | — | 50 | 40 | | |
| 5730 65210120 | -120 | 1 | 10 | 120 | 64 | 28 | 30 | 52 | — | 70 | 40 | | |
| 5730 65211090 | HSK63F -PHC11A-90 | 1 | 11 | 90 | 45 | 30 | 32 | 52 | — | 50 | 40 | | |
| 5730 65211120 | -120 | 1 | 11 | 120 | 65 | 30 | 32 | 52 | — | 70 | 40 | | |
| 5730 65212090 | HSK63F -PHC12A-90 | 1 | 12 | 90 | 45 | 30 | 32 | 52 | — | 50 | 40 | | |
| 5730 65212120 | -120 | 1 | 12 | 120 | 65 | 30 | 32 | 52 | — | 70 | 40 | | |
| 5730 65213090 | HSK63F -PHC13A-90 | 1 | 13 | 90 | 46 | 34 | 36 | 52 | — | 50 | 40 | | |
| 5730 65213120 | -120 | 1 | 13 | 120 | 66 | 34 | 36 | 52 | — | 70 | 40 | | |
| 5730 65214090 | HSK63F -PHC14A-90 | 1 | 14 | 90 | 46 | 34 | 36 | 52 | — | 50 | 40 | | |
| 5730 65214120 | -120 | 1 | 14 | 120 | 66 | 34 | 36 | 52 | — | 70 | 40 | | |
| 5730 65215090 | HSK63F -PHC15A-90 | 1 | 15 | 90 | 46 | 36 | 38 | 52 | — | 50 | 40 | | |
| 5730 65215120 | -120 | 1 | 15 | 120 | 66 | 36 | 38 | 52 | — | 70 | 40 | | |
| 5730 65216090 | HSK63F -PHC16A-90 | 1 | 16 | 90 | 46 | 36 | 38 | 52 | — | 50 | 40 | | |
| 5730 65216120 | -120 | 1 | 16 | 120 | 66 | 36 | 38 | 52 | — | 70 | 40 | | |
| 5730 65220090 | HSK63F -PHC20A-90 | 1 | 20 | 90 | 49 | 40 | 42 | 46 | — | 50 | 40 | | |
| 5730 65220120 | -120 | 1 | 20 | 120 | 69 | 40 | 42 | 46 | — | 70 | 40 | | |
| 5730 65225135 | HSK63F -PHC25A-135 | 2 | 25 | 135 | 59 | 50 | 52 | 59 | 42 | 60 | 50 | | L-6T (6mm) |
| 5730 65225150 | -150 | 2 | 25 | 150 | 79 | 50 | 52 | 59 | 42 | 80 | 50 | | |
| 5730 65232135 | HSK63F -PHC32A-135 | 2 | 32 | 135 | 42 | 60 | 62 | 85 | 42 | 80 | 65 | | |
| 5730 65232150 | -150 | 2 | 32 | 150 | 108 | 60 | 62 | 62 | 42 | 80 | 65 | | |

1. Please use a cutting tool with a tolerance of less than h7. A tolerance of less than 0/-001 is recommended for new cutting tools.
2. Do not leave the holder with actuating screw tightened when the chuck is empty.
3. PHC12A and PHC20A have pin holes for collet with stopper pin on its body.

Ordering Example

HSK63F - PHC 12 A - 135
 Shank size I.D. (d) Projection length (L)

| Tightening torque (Torque wrench : p.498) | | |
|---|----------------|---------------------------|
| model | I.D. (d) mm | Tightening torque (Nm) |
| PHC-A | 06 ~ 08 | 11 ~ 12 |
| PHC-A | 09 ~ 20 | 7 ~ 8 |
| PHC-A | 25, 32 | 29 ~ 30 |

