

Drill Jig Bushing

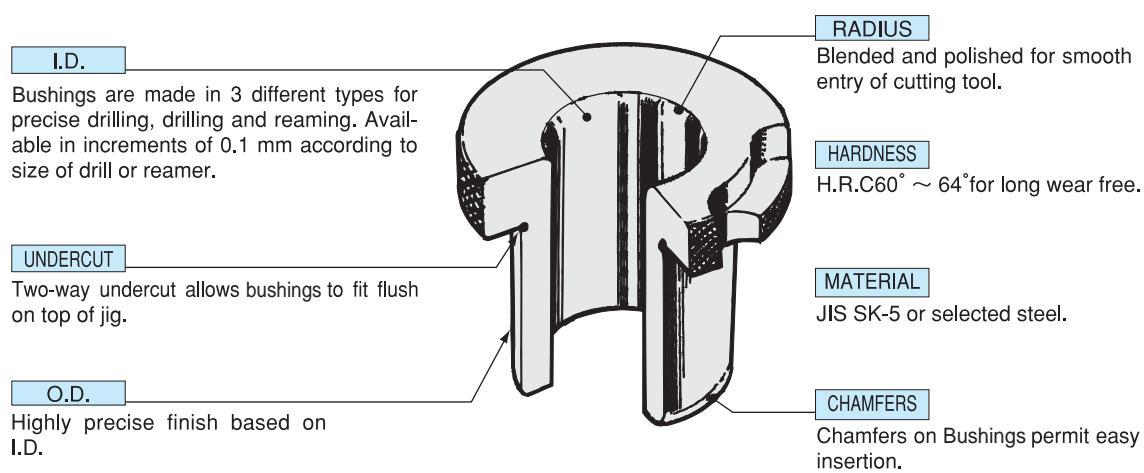

Type	PRESS FIT BUSHING		RENEWABLE BUSHING
Designation	HEADLESS Type A	HEADED Type B	ROUND Type C
Tool applied			
Shape and sequence of fitting-in			
Sectional view			

HOW TO INSTALL A JIG BUSHING	
PRESS FIT BUSHING Type A, B, G	RENEWABLE BUSHING Type C, D, E, F
<p>How to press-fit</p> <p>Press the bushing correctly into the bush plate.</p>	<p>Renewable bushing can be inserted by hand.</p>

Bushings that have the same O.D. are interchangeable with each other.

LINER BUSHING Type G

This Guides the renewable bushing for smoother insertion or replacement.

Name	Press fit bushing		Renewable bushing				Headless liner bushing	Lock screw	Round clamp
	Headless	Headed	Round	Right slip	Left slip	Fixed			
Shape									
Higher accuracy	SA	SB	SC	SD	SE	SF	G	T	R
Standard accuracy	A	B	C	D	E	F			
Reaming	—	BR	CR	DR	ER	FR			

S...for higher accuracy R...for reaming

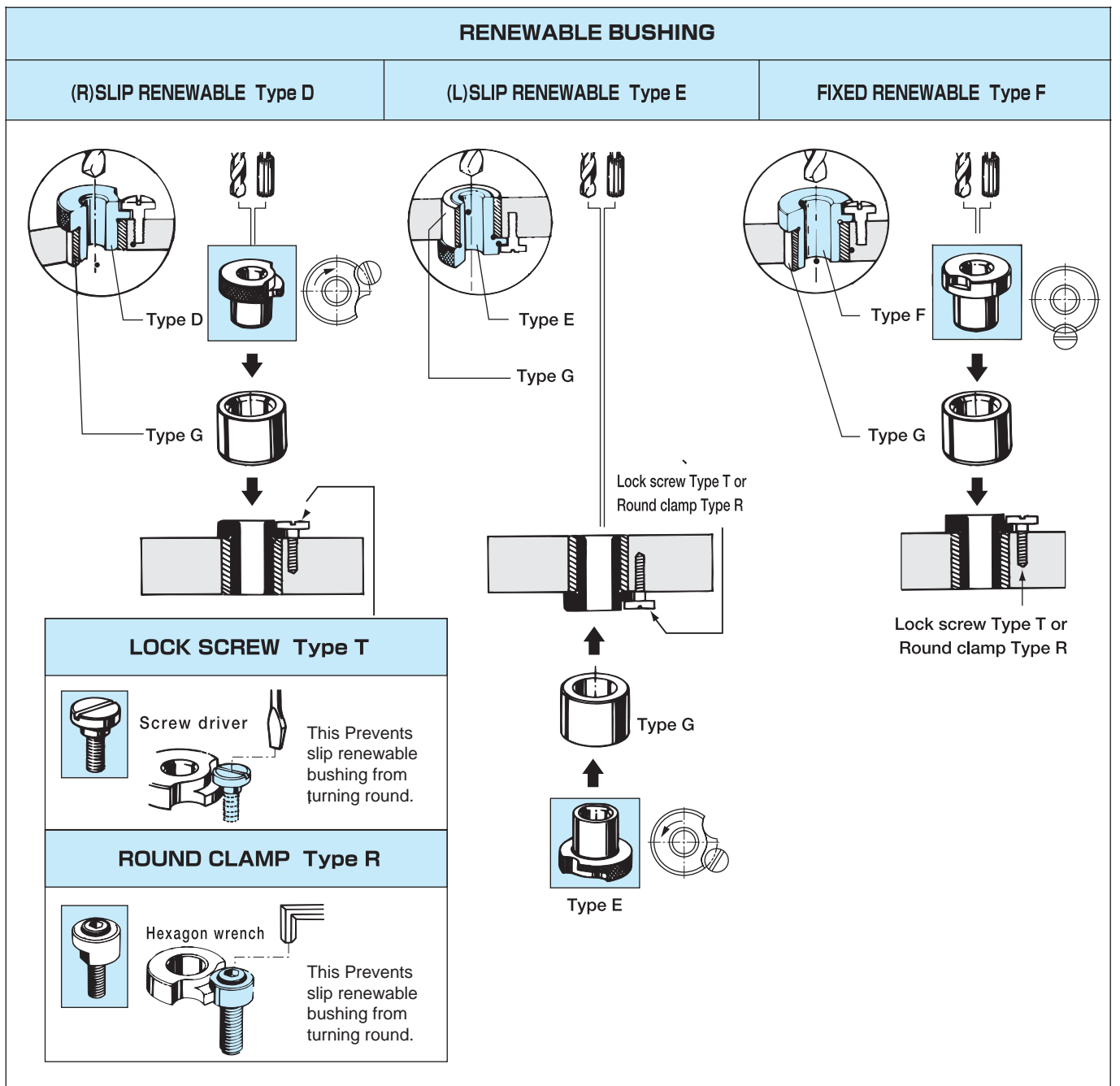

Type F

Fixed Renewable Bushing Type F

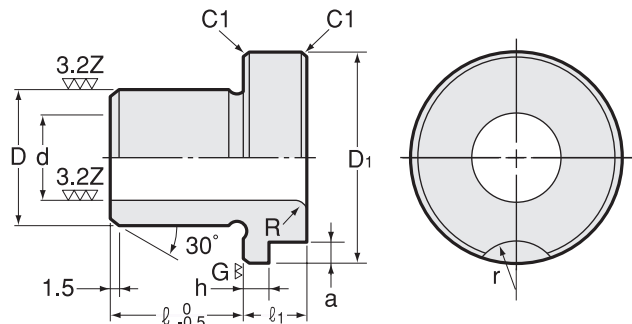

Example

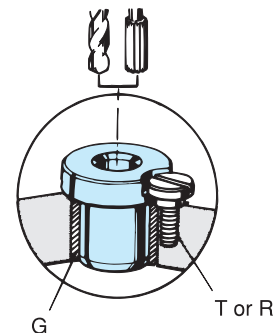

※ 1. Bushing with I.D. size smaller than 3.0mm uses 30 degree chamfered radius (R).

Application

Fixed renewable bushing can be used continuously when products are made in high volume.

Tolerance of I.D.

d	1.6 ~ 3.0	3.1 ~ 6.0	6.1 ~ 10.0	10.1 ~ 18.0	18.1 ~ 30.0	30.1 ~ 42.0
SF (G6)	+0.008 +0.002	+0.012 +0.004	+0.014 +0.005	+0.017 +0.006	+0.020 +0.007	+0.025 +0.009
F	+0.025 +0.002	+0.030 +0.004	+0.036 +0.005	+0.043 +0.006	+0.052 +0.007	+0.062 +0.009
FR	+0.014 +0.008	+0.020 +0.012	+0.024 +0.015	+0.029 +0.018	+0.034 +0.021	+0.041 +0.025

Concentric runout (T.I.R.) of O.D.to I.D.

d	1.6 ~ 18.0	18.1 ~ 42.0
SF/FR	0.005 or less	0.008 or less
F	0.012 or less	0.020 or less

- 1.Fixed renewable bushing must be used in combination with headless liner bushing (Type G).
- 2.O.D.(D) of fixed renewable bushing must coincide with I.D.(d) of headless liner bushing.

SF.....For higher accuracy
 F.....For standard accuracy
 FR.....For reaming

d	D (m5)		D1	ℓ 1	h	a	R	r	Lock screw Round clamp	Grade	ℓ						
											12	16	20	25	30	35	45
1.6 ~ 2.0	8 +0.012 +0.006		16	8	3.5	3	※ 1	7	T-5	SF	○						
										R-5	F	○					
2.1 ~ 3.0	8 +0.012 +0.006		16	8	3.5	3	※ 1	7	T-5	SF	○						
										R-5	F	○					
3.1 ~ 4.0	8 +0.012 +0.006		16	8	3.5	3	1	7	T-5	SF	○	○					
										R-5	F	○	○				
4.1 ~ 6.0	10 +0.012 +0.006		19	8	3.5	3	1	7	T-5	SF	○	○					
										R-5	F	○	○				
6.1 ~ 8.0	12 +0.015 +0.007		22	8	3.5	3	2	7	T-5	SF		○	○				
										R-5	F		○	○			
8.1 ~ 10.0	15 +0.015 +0.007		26	9	3.5	3	2	7	T-5	SF		○	○				
										R-5	F		○	○			
10.1 ~ 12.0	18 +0.015 +0.007		30	9	3.5	3	2	7	T-5	SF			○	○			
										R-5	F			○	○		
12.1 ~ 15.0	22 +0.017 +0.008		35	12	5	4	2	9	T-6	SF			○	○			
										R-6	F			○	○		
15.1 ~ 18.0	26 +0.017 +0.008		40	12	5	4	2	9	T-6	SF				○	○		
										R-6	F				○	○	
18.1 ~ 22.0	30 +0.017 +0.008		47	12	5	4	3	9	T-6	SF				○	○		
										R-6	F				○	○	
22.1 ~ 26.0	35 +0.020 +0.009		55	15	6	5	3	10	T-8	SF					○	○	
										R-8	F					○	○
26.1 ~ 30.0	42 +0.020 +0.009		62	15	6	5	3	10	T-8	SF					○	○	
										R-8	F					○	○
30.1 ~ 35.0	48 +0.020 +0.009		69	15	6	5	4	10	T-8	SF						○	○
										R-8	F						○
35.1 ~ 42.0	55 +0.024 +0.011		77	15	6	5	4	10	T-8	SF						○	○
										R-8	F						○

List prices of type FR are identical to those of type SF.

Ordering Example

SF - 6.0 × 12
 d ℓ

Code

0000 062 060 12
 Code
 F:061
 SF:062
 FR:063

BT

CAT

AHO

HSK-A/E/F/C

HSK-T

UTS

Specialized Machine

Related Equipment

Bushing & Chamfering Drill

Drill Jig Bushing

Chamfering Cutter Series

Chamfering Series