

# SBT

## HSK-T Turning Tools

- For External / Facing

BT
CAT
AHO
HSK-A/E/F/C
<b>HSK-T</b>
UTS
Specialized Machine
Related Equipment
Bush & Chamfering Drill
Turning Tools

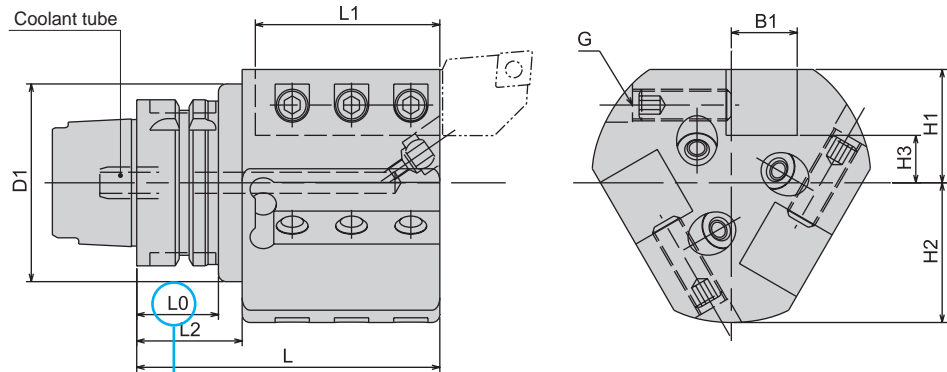

**Caution**  
 ★ Take caution against A.T.C. arm and tool magazine interference.

Right-hand drawing shown

- Coolant tube is included.

### Metric Sizes Unit : Metric

Code	Model	L	L1	L2	D1	B1	H1	H2	H3	L0	G	Kg
590004140095	<b>HSK50T -SBT2020 R -95</b>	95	60	—	—	20	35	43.5	15	31	M10	2.3
590004141095	<b>L -95</b>	95	60	—	—	20	35	43.5	15	31	M10	2.3
590005140095	<b>HSK63T -SBT2020 R -95</b>	95	60	—	—	20	35	43.5	15	32	M10	2.6
590005141095	<b>L -95</b>	95	60	—	—	20	35	43.5	15	32	M10	2.6
590005150115	<b>-SBT2525 R -115</b>	115	70	40	90	25	43	53	18	32	M12	4.4
590005151115	<b>L -115</b>	115	70	40	90	25	43	53	18	32	M12	4.4
590007150150	<b>HSK100T -SBT2525 R -150</b>	150	110	—	—	25	48	59	23	35	M12	8.9
590007151150	<b>L -150</b>	150	110	—	—	25	48	59	23	35	M12	8.9

- 1.Direction of coolant nozzle can be adjusted. (Coolant may not reach the cutting edge properly depending on the bit shape.)
- 2.Please shorten square bits if necessary.
- 3.Two plug screws for coolant nozzle (M5x15) are included.
- 4.HSK-T type has no manual clamping hole and ID chip recess.

**Ordering Example**  
**HSK63T - SBT 2020 R - 95**  
 Shank size                      □ Left hand - L      Projection length (L)  
    □ Right hand - R