

ED · A

Straight Drill Chuck

ST Type1

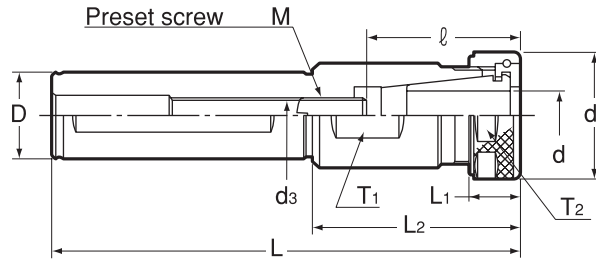

ST Type2

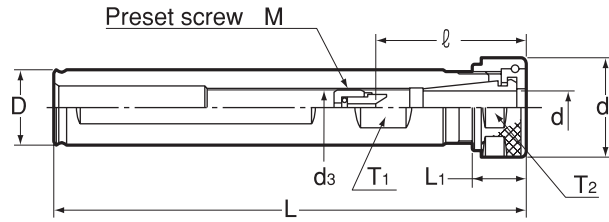

ST Type3

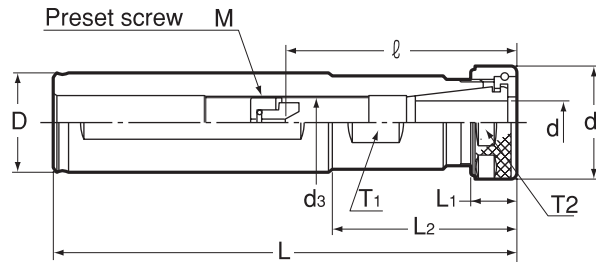

Code	Model	Chucking range (d)	Type	D _{h6}	L	d1	L1	L2	M	d3	ℓ	T1	T2	Nut	kg
0060 52001619	ED -1619A	2.8 ~ 9	1	16	125	26	14	50	M8	6.8	30 ~ 40	17	24	KDP-1916	0.2
0060 52002019	-2019A	2.8 ~ 9	2	20	125	26	14	—	M10	9.3	30 ~ 60	17	24	KDP-1916	
0060 52002219	-2219A	2.8 ~ 9	3	22	125	26	14	50	M10	9.3	30 ~ 60	17	24	KDP-1916	
0060 52002519	-2519A	2.8 ~ 9	3	25	125	26	14	50	M10	9.3	30 ~ 60	17	24	KDP-1916	
0060 52025419	-25419A	2.8 ~ 9	3	25.4	125	26	14	50	M10	9.3	30 ~ 60	17	24	KDP-1916	
0060 52031719	-317519A	2.8 ~ 9	3	31.75	150	26	14	60	M10	9.3	30 ~ 60	17	24	KDP-1916	
0060 52003219	-3219A	2.8 ~ 9	3	32	150	26	14	60	M10	9.3	30 ~ 60	17	24	KDP-1916	
0060 52002028	ED -2028A	4 ~ 16	1	20	135	36	15	60	M10	8.6	43 ~ 55	27	33	KDP-2825	0.4
0060 52002228	-2228A	4 ~ 16	1	22	135	36	15	60	M10	8.6	43 ~ 55	27	33	KDP-2825	0.4
0060 52002528	-2528A	4 ~ 16	1	25	135	36	15	60	M10	8.6	43 ~ 55	27	33	KDP-2825	0.5
0060 52025428	-25428A	4 ~ 16	1	25.4	135	36	15	60	M10	8.6	43 ~ 55	27	33	KDP-2825	0.5
0060 52031728	-317528A	4 ~ 16	3	31.75	150	36	15	60	M17	16.3	43 ~ 75	27	33	KDP-2825	0.6
0060 52003228	-3228A	4 ~ 16	3	32	150	36	15	60	M17	16.3	43 ~ 75	27	33	KDP-2825	0.6
0060 52004028	-4028A	4 ~ 16	3	40	175	36	15	75	M17	16.3	43 ~ 75	27	33	KDP-2825	1.1
0060 52004228	-4228A	4 ~ 16	3	42	175	36	15	75	M17	16.3	43 ~ 75	27	33	KDP-2825	1.1

Collet and spanner are sold separately.

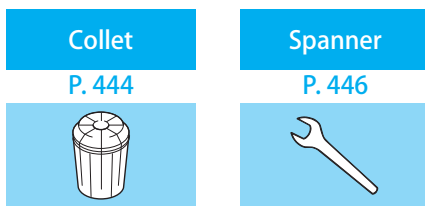

Accessories			
Model	Nut (Included)	Collet	Spanner
ED-○○19A	KDP-1916	EDC-d19	S-1L
ED-○○28A	KDP-2825	EDC-d28	S-4L

Ordering Example

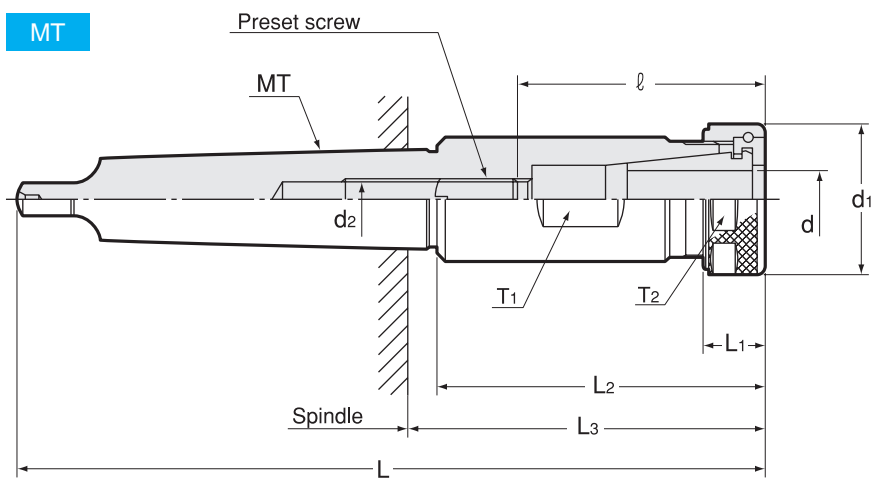

ED - 16 19A
D 19Aseries

- BT
- CAT
- AHO
- HSK-A/E/F/C
- HSK-T
- UTS
- Specialized Machine
- Related Equipment
- Bush & Chamfering Drill
- Sub Holder
- Tapping Chuck
- Tap Adapter
- Adjustable Adapter
- Endmill Chuck
- Straight Drill Chuck
- Floating Holder

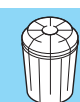

Code	Model	d Chucking range	MT	L	d1	L1	L2	M	L3	d2	ℓ	T1	T2	Nut	kg
0060 52000119	ED -T119A	2.8 ~ 9	1	120	26	14	50	—	58	—	30	17	24	KDP-1916	0.1
0060 52000219	-T219A	2.8 ~ 9	2	150	26	14	65	M10	75	9.3	30 ~ 60	17	24	KDP-1916	0.2
0060 52000319	-T319A	2.8 ~ 9	3	180	26	14	80	M10	86	9.3	30 ~ 60	17	24	KDP-1916	0.3
0060 52000228	-T228A	4 ~ 16	2	150	36	15	65	M8	75	6.8	43 ~ 55	27	33	KDP-2825	0.4
0060 52000328	-T328A	4 ~ 16	3	180	36	15	80	M10	86	8.6	43 ~ 55	27	33	KDP-2825	0.6
0060 52000428	-T428A	4 ~ 16	4	205	36	15	80	M17	88	16.3	43 ~ 75	27	33	KDP-2825	0.8

Collet and spanner are sold separately. (P. 444 - 446)

<p>Collet</p> <p>P. 444</p> 	<p>Spanner</p> <p>P. 446</p> 
--	---

Accessories			
Model	Nut (Included)	Collet	Spanner
ED-○○19A	KDP-1916	EDC-d19	S-1L
ED-○○28A	KDP-2825	EDC-d28	S-4L

Ordering Example

ED - T1 19A
Shank size 19Aseries

ED For Small Diameters

Straight Drill Chuck For Small Diameters

Tr Type1

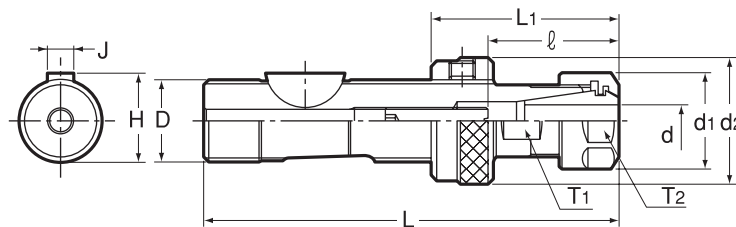

ST Type2

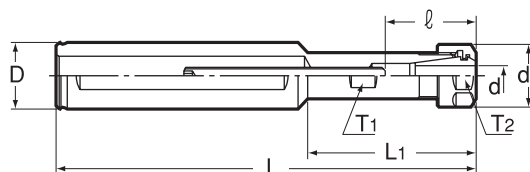

MT Type3

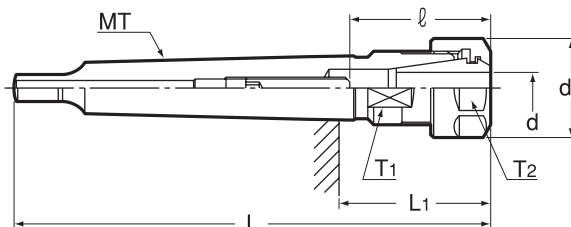

Code	Model	d Chucking range	Type	D _{h6}	MT	L	d1	d2	ℓ	L1	H _{0-0.2}	J _{h9}	T1	T2	Nut	kg	Collet
0060 50011007	ED -Tr1007/Tr10	0.5 ~ 7	1	10	-	72	19	18	18 ~ 31 (21)	32 ~ 42	10.9	3	12	17	KDP-1414	0.1	FDC-07
0060 50011207	-Tr1207/Tr12	0.5 ~ 7	1	12	-	72	19	20	18 ~ 31	32 ~ 42	12.9	3	12	17	KDP-1414	0.1	
0060 50011607	-Tr1607/Tr16	0.5 ~ 7	1	16	-	80	19	25	18 ~ 31	35 ~ 45	17.1	5	12	17	KDP-1414	0.1	
0060 50001607	ED -1607	0.5 ~ 7	2	16	-	125	19	-	18 ~ 31	50	-	-	12	17	KDP-1414	0.1	FDC-07
0060 50002007	-2007	0.5 ~ 7	2	20	-	125	19	-	18 ~ 31	50	-	-	12	17	KDP-1414	0.2	
0060 50000007	ED -T007	0.5 ~ 7	3	-	0	85.5	19	-	18 ~ 31 (21)	29	-	-	12	17	KDP-1414		FDC-07
0060 50000107	-T107	0.5 ~ 7	3	-	1	91.5	19	-	18 ~ 31	29	-	-	12	17	KDP-1414		

1. Collet are sold separately. (P. 444)

2. ℓ dimension in bracket is valid only when the tool shank is φ5.1mm or bigger.

Collet

P. 444



Accessories

Holder Model	Nut (Included)	Collet	Spanner
All Model	KDP-1414	FDC-07	Width 17mm

Ordering Example

ED - 16 07
D 07series

Spindle Dimensions for ED-07 series

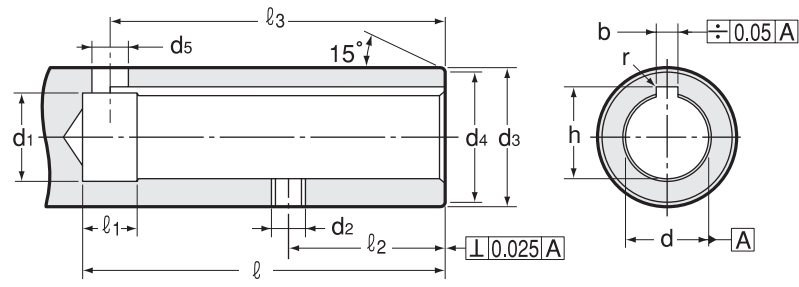

寸法 Size	d H6	ℓ (min)	d1	d2	d3 g6	d4	d5	ℓ 1	ℓ 2 ± 0.1	ℓ 3	b	h +0.1 0
10	10	41	10.6	M5	18	17.4	5	8	14	37	3 +0.012 +0.06	11
12	12	41	12.6	M5	20	19.2	5	8	14	37	3 +0.012 +0.06	13
16	16	46	16.6	M6	25	24	6	8	16	42	5 +0.145 +0.07	17.3

Special spindle dimension shown above is different from DIN standard.

- BT
- CAT
- AHO
- HSK-A/E/F/C
- HSK-T
- UTS
- Specialized Machine
- Related Equipment
- Bush & Chamfering Drill
- Sub Holder
- Tapping Chuck
- Tap Adapter
- Adjustable Adapter
- Endmill Chuck
- Straight Drill Chuck
- Floating Holder