

# Shrink Fit Heating System

## SRK/HB2

### Economy Type Heater

#### Economy type Heating System

#### SRK-HB2 (3000W)

- Economical
- Simple Operation
- Compact
- Heating Time : 1-9min

When Ordering a heater, Please select both heat distributor and holder support to meet your requirement.  
Available in all taper sizes (HSK, BT, CAT).

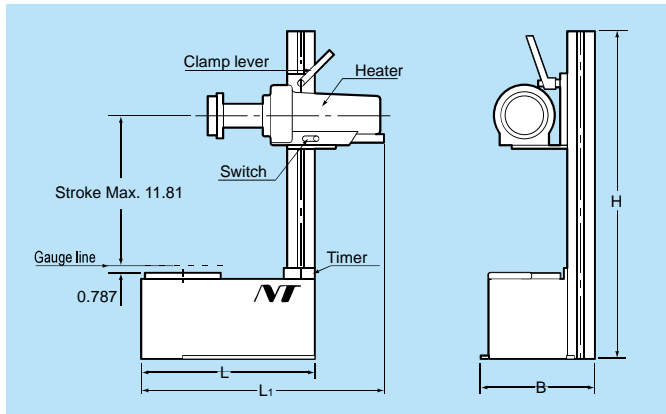

#### Application

- Heating system for thermal expansion of shrink fit holders.
- Heat generation = 482 - 662° F

#### Specifications

- Heating method : Hot air
- Pwer Supply : 200 - 230V / 50,60Hz
- Rated ampere : 6A (200-230V)
- Accessories : Power cord (3m) ,countdown timer and a pair of heat-resistant gloves are included. (Hot air distributor and holder support are sold separately.)
- Cemented carbide shank tool (with h6 tolerance) should be used.

Part Number	L	B	H	L <sub>1</sub>	VAC	lbs
SRK -HB2-200	10.83	7.48	25.98	16.38	200	16.5 (7.5kg)
-HB2-220					220	
-HB2-230					230	

#### Ordering Example:

Heater SRK-HB2 + Hot Air Distributor + Holder Support + Accessories

#### ■ Hot air distributor (Heating head)

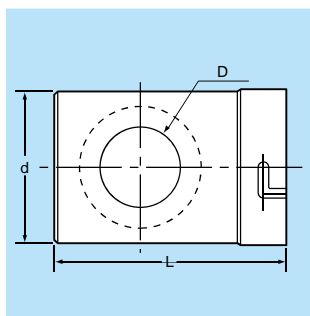

Part Number	Chuck	Tool dia.	D	d	L
SRK-HA	SRD type	φ0.984 - 1.26	1.575	3.110	4.803
		φ0.472 - 0.787	1.260	2.402	3.661
		φ0.236 - 0.394	1.024	1.693	3.346
	SRS type	φ0.118 - 0.197	0.591	1.693	3.346
		φ0.472 - 0.787	1.063	2.402	3.425
		φ0.118 - 0.394	0.591	1.693	3.031

#### ■ Holder Support

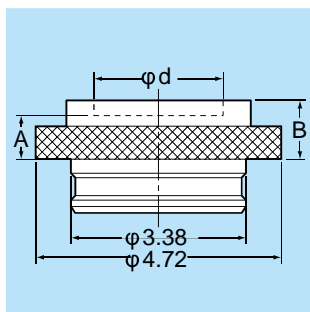

Part Number	d	A	B
SRK-SP	-HSK25	0.787	1.063
	-HSK32		
	-HSK40		
	-BT30		
	-HSK63, BT40, CAT40		
	-HSK100, BT50, CAT50		1.181

# Shrinker Fit Heating System Accessories SPN - SRK

## Accessories

### ■ Presetting gauge

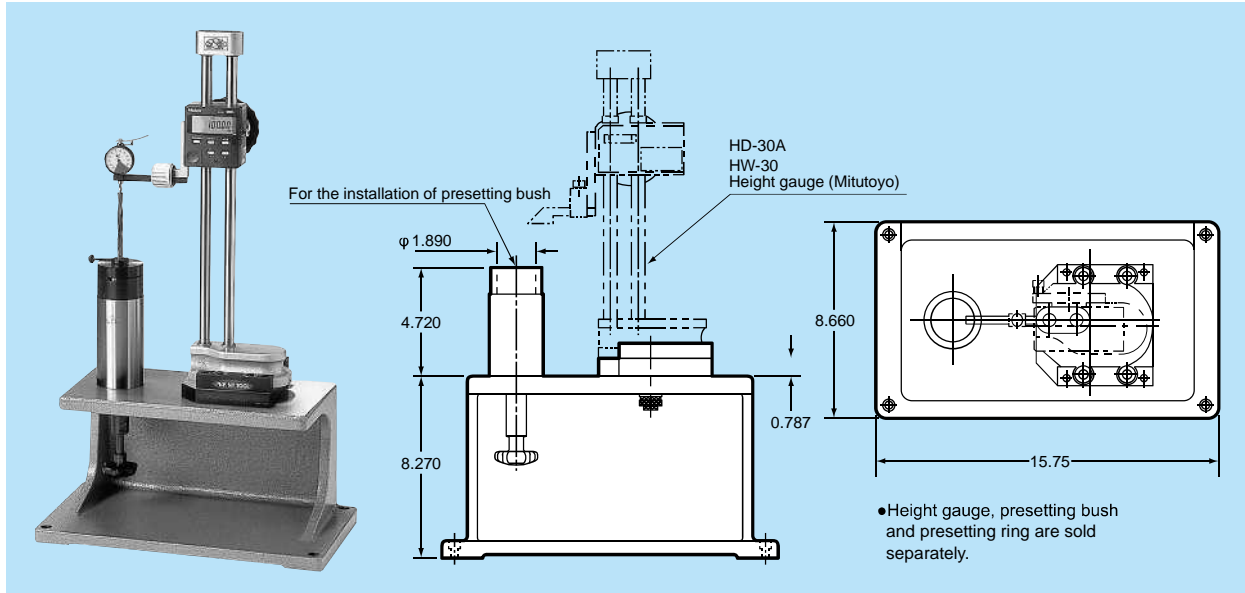

Part Number
SPN2-SRK-PS1

### ■ Presetting bush

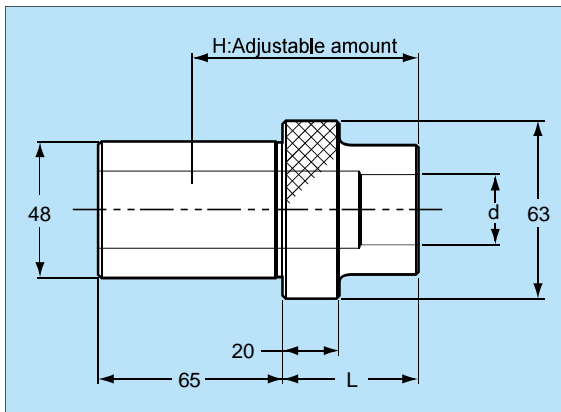

Model	φd	L	H
-SRK3-B1	3	0.394	0.394 - 2.165
-SRK4-B1	4	0.472	0.472 - 2.244
-SRK5-B1	5	0.591	0.591 - 2.362
-SRK6-B1	6	1.024	1.024 - 2.795
-SRK8-B1	8		
-SRK10-B1	10	1.260	1.260 - 3.031
-SRK12-B1	12	1.457	1.457 - 3.228
-SRK14-B1	14		
-SRK16-B1	16	1.575	1.575 - 3.346
-SRK18-B1	18		
-SRK20-B1	20	1.654	1.654 - 3.425
-SRK20-B2		2.165	2.165 - 3.937
-SRK25-B1	25	1.890	1.890 - 3.661
-SRK25-B2		2.559	2.559 - 4.331
-SRK32-B1	32	2.008	2.008 - 3.780
-SRK32-B2		2.953	2.953 - 4.724

### ■ Presetting ring

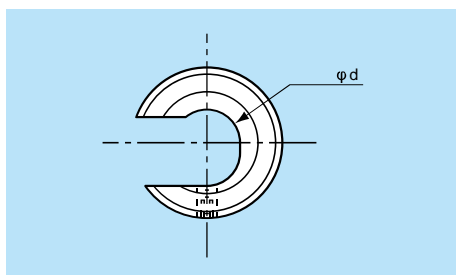

Part Number	φ d (mm)
SPN2-SRK-PR-φ d	3, 4, 5, 6, 8, 10, 12, 14, 16, 18, 20, 25, 32