

Simple Setter SPHV-3

SPHV-3



■ Features

- Light-weight and compact. Can be installed on a Workbench.
- Digital scale is used for both X and Z-axis.
- Affordable price.
- Easily adapted for “Tool Identification” systems.

■ Applications

When placed beside machining centers, height and diameter adjustments can be made easily.

Simple Setter SPHV-3

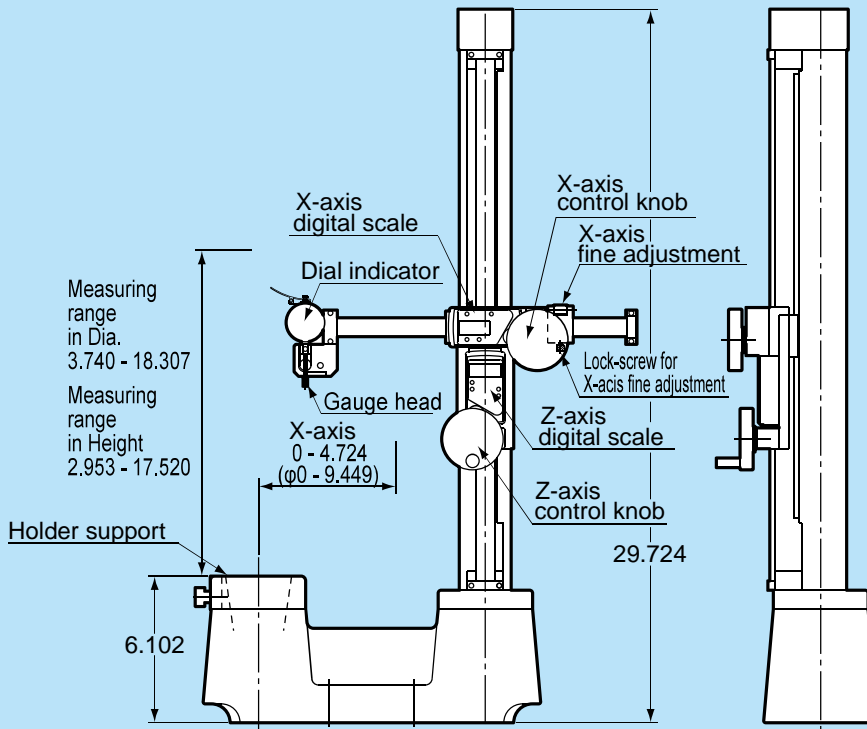
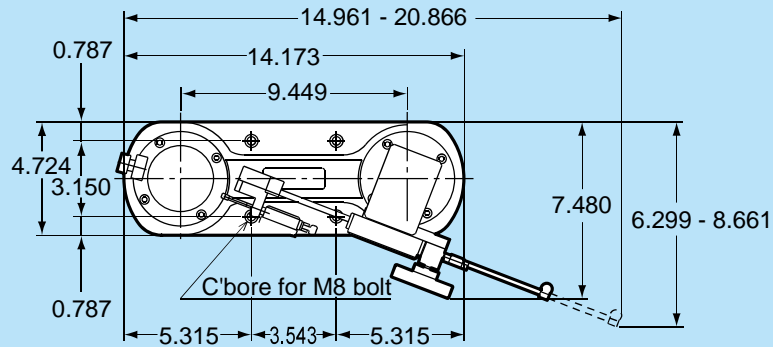

Part Number	Taper size	Measurement range (in)	Minimum readable unit	Increment holder support
SPHV-3	-30	30	X 0 - ϕ 9.449	NTSP-30
	-40	40	Z height measurement 2.953 - 17.52	NTSP-40
	-50	50	diameter measurement 3.74 - 18.307	NTSP-50

- * A suitable master arbor (GL=5.906 in) is included.
- * A longer master arbor (GL=11.811in) is available upon request.
- * For BT shank only.