

Simple Setter

SPHV-3



Features

Light-weight and compact. Can be installed on a Workbench.

Digital scale is used for both X and Z-axis.

Affordable price.

Easily adapted for “ Tool Identification ” systems.

Applications

When placed beside machining centers, height and diameter adjustments can be made easily.

Simple Setter SPHV-3

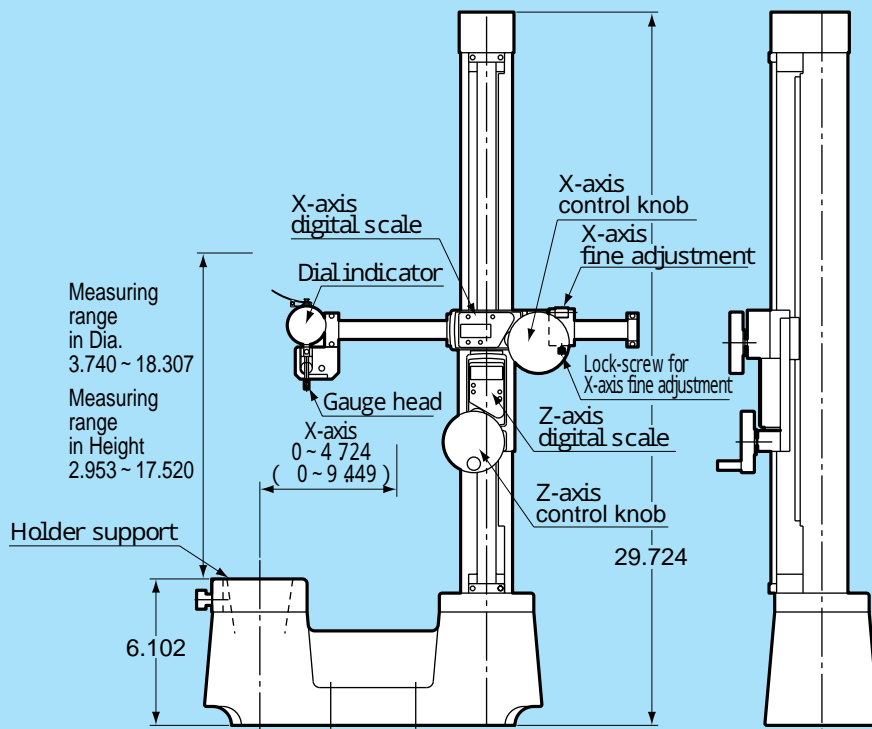
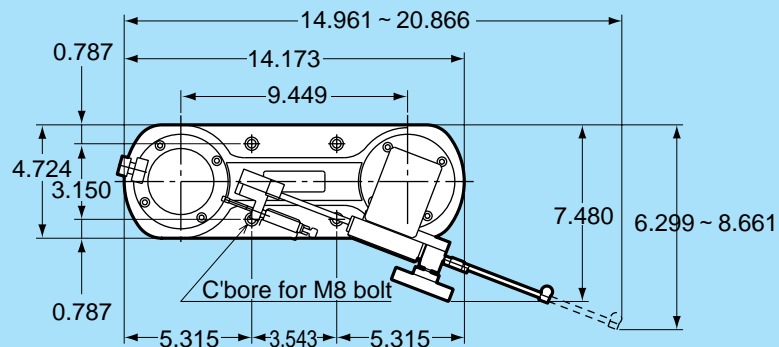

Part Number	Taper size	Measurement range(in)	Minimum readable unit	Increment holder support
SPHV-3	-30	30	X 0 ~ 9.449	NTSP-30
	-40	40	Z height measurement 2.953 ~ 17.52	NTSP-40
	-50	50	diameter measurement 3.74 ~ 18.307	NTSP-50

*A suitable master arbor (GL=5.906in) is included.

*A longer master arbor (GL=11.811in) is available upon