

Quick Change Stub Holder KH-EC1 for high coolant pressure

Feature In addition to KH-E' s outstanding features, KH/EC1 and KH/EC2 have the ability for center-thru coolant feeding.

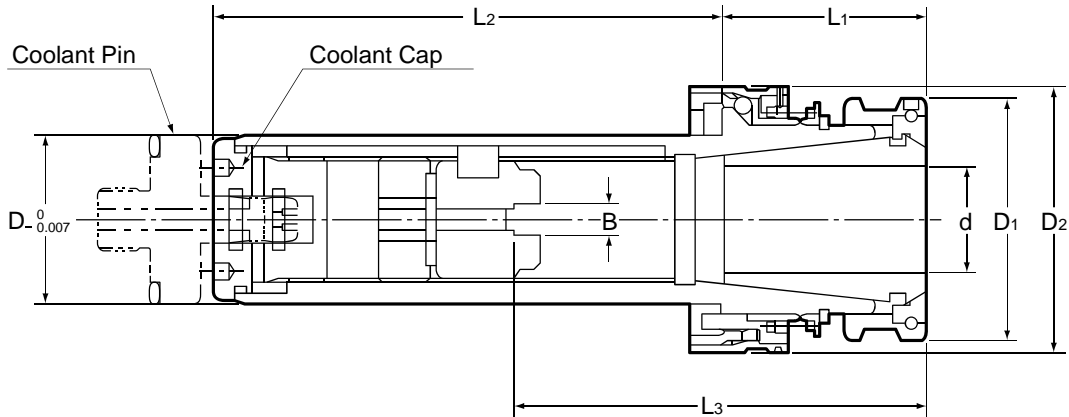

| Part Number | Coolant Pin | D | Collet I.D. d | B | L ₃ | D ₁ | D ₂ | L ₁ | L ₂ | Collet | Coolant Pressure MAX |
|---|-------------|-----------|---------------|--------------|----------------|----------------|----------------|----------------|----------------|-----------------|----------------------|
| KHB -14EC1 / 00007 / 02407 / 03007 / 04007 | KH-14EC-P | 14 | 3.0 - 7.0 | 0 | 23 - 43 | 23 | 26.3 | 34 | 50 | FDC-07-OH | 8 MPa |
| | | | 3.1 - 5.0 | 2.4 | | | | | | | |
| | | | 5.1 - 6.0 | 3.0 | 25 - 46 | | | | | | |
| | | | 6.1 - 7.0 | 4.0 | | | | | | | |
| KHB -16EC1 / 00009 / 02409 / 03009 / 04009 | KH-16EC-P | 16 | 3.0 - 9.0 | 0 | 29 - 45 | 26 | 32 | 35 | 55 | FDC-09 -OH or C | |
| | | | 3.1 - 5.0 | 2.4 | | | | | | | |
| | | | 5.1 - 6.0 | 3.0 | 32 - 49 | | | | | | |
| | | | 6.1 - 9.0 | 4.0 | | | | | | | |
| KHB -19EC1 / 00009 / 02409 / 03009 / 04009 | KH-19EC-P | 19 | 3.0 - 9.0 | 0 | 29 - 50 | 26 | 35 | 35 | 60 | FDC-09 -OH or C | |
| | | | 3.1 - 5.0 | 2.4 | | | | | | | |
| | KH-20EC-P | 20 | 5.1 - 6.0 | 3.0 | 32 - 54 | | | | | | |
| | | | 6.1 - 9.0 | 4.0 | | | | | | | |
| KHB -22EC1 / 00012 / 02412 / 03012 / 04012 / 05012 | KH-22EC-P | 22 | 3.0 - 12 | 0 | 35 - 57 | 32 | 38 | 35 | 70 | FDC-12 -OH or C | |
| | | | 3.1 - 5.0 | 2.4 | | | | | | | |
| | KH-24EC-P | 24 | 5.1 - 6.0 | 3.0 | 33 - 60 | | | | | | |
| | | | 6.1 - 9.0 | 4.0 | | | 37 - 64 | | | | |
| KHB -25EC1 / 00016 / 03016 / 04016 / 05016 / 06016 | KH-25EC-P | 25 | 6.0 - 16 | 0 | 38 - 60 (65) | 36 | | 44 | 35 | 80 | FDC-16 -OH or C |
| | | | 6.0 | 3.0 | | | | | | | |
| | KH-28EC-P | 28 | 6.1 - 9.0 | 4.0 | 39 - 58 (63) | | | | | | |
| | | | 9.1 - 12 | 5.0 | | | 42 - 64 (69) | | | | |
| KH-30EC-P | 30 | 12.1 - 16 | 6.0 | 47 - 69 (74) | | | | | | | |
| | | | | | 50 - 72 (77) | | | | | | |
| KHB -32EC1 / 00022 / 03022 / 04022 / 05022 / 06022 / 08022 | KH-32EC-P | 32 | 6.0 - 22 | 0 | | 38 - 74 | 46 | 51 | 40 | 100 | FDC-22 -OH or C |
| | | | 6.0 | 3.0 | | | | | | | |
| | KH-35EC-P | 35 | 6.1 - 9.0 | 4.0 | 39 - 75 | | | | | | |
| | | | 9.1 - 12 | 5.0 | | 42 - 78 | | | | | |
| KH-36EC-P | 36 | 12.1 - 16 | 6.0 | 48 - 84 | | | | | | | |
| | | 16.1 - 22 | 8.0 | | 54 - 87 | | | | | | |
| | | | | | | | 55 | | | | 6 MPa |

Ordering Example

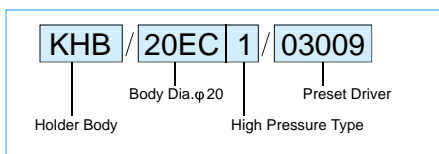

- All dimensions shown in millimeters.
- L₃ in brackets stands for the KHB-28EC1 and KH-30EC1 dimensions only
- For adjusting the preset screw, remove the coolant cap.
- Coolant pin, coolant collet and spanner wrench are sold separately. (Page 60,208)

Quick Change Stub Holder KH-EC2 for low coolant pressure

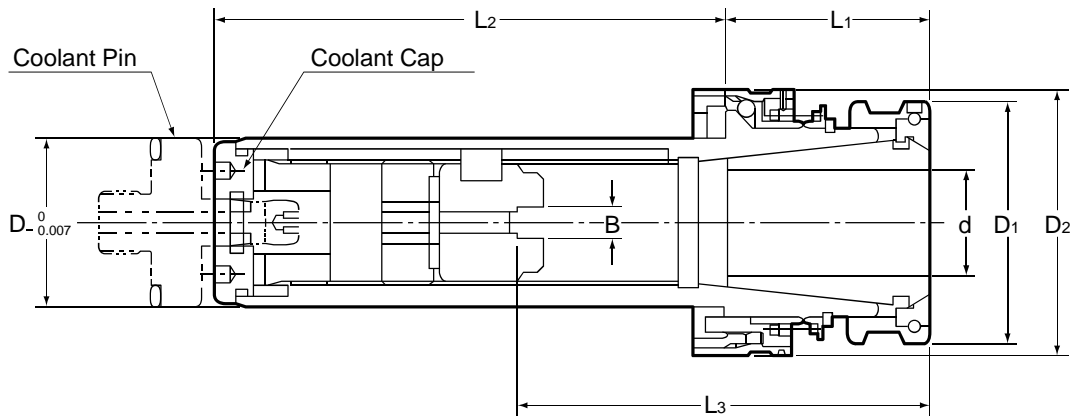

| Part Number | Coolant Pin | D | Collet I.D. d | B | L ₃ | D ₁ | D ₂ | L ₁ | L ₂ | Collet | Coolant Pressure MAX | |
|---|-------------|----|------------------|-----|----------------|----------------|----------------|----------------|----------------|--------------------|----------------------|------|
| KHB -14EC2 / 00007 / 02407 / 03007 / 04007 | KH-14EC-P | 14 | 3.0 - 7.0 | 0 | 23 - 43 | 23 | 26.3 | 34 | 50 | FDC-07-OH | 5 MPa | |
| | | | 3.1 - 5.0 | 2.4 | | | | | | | | |
| | | | 5.1 - 6.0 | 3.0 | 25 - 46 | | | | | | | |
| | | | 6.1 - 7.0 | 4.0 | | | | | | | | |
| KHB -16EC2 / 00009 / 02409 / 03009 / 04009 | KH-16EC-P | 16 | 3.0 - 9.0 | 0 | 29 - 45 | 26 | 32 | 35 | 55 | FDC-09 -OH or C | | |
| | | | 3.1 - 5.0 | 2.4 | | | | | | | | |
| | | | 5.1 - 6.0 | 3.0 | 32 - 49 | | | | | | | |
| | | | 6.1 - 9.0 | 4.0 | | | | | | | | |
| KHB -19EC2 / 00009 / 02409 / 03009 / 04009 | KH-19EC-P | 19 | 3.0 - 9.0 | 0 | 29 - 50 | 26 | 35 | 35 | 60 | FDC-09 -OH or C | | |
| | | | 3.1 - 5.0 | 2.4 | | | | | | | | |
| | KH-20EC-P | 20 | 5.1 - 6.0 | 3.0 | 32 - 54 | | | | | | | |
| | | | 6.1 - 9.0 | 4.0 | | | | | | | | |
| KHB -22EC2 / 00012 / 02412 / 03012 / 04012 / 05012 | KH-22EC-P | 22 | 3.0 - 12 | 0 | 35 - 57 | 32 | 38 | 35 | 70 | FDC-12 -OH or C | 4 MPa | |
| | | | 3.1 - 5.0 | 2.4 | | | | | | | | |
| | KH-24EC-P | 24 | 5.1 - 6.0 | 3.0 | 33 - 60 | | | | | | | |
| | | | 6.1 - 9.0 | 4.0 | | | | | | | | |
| KHB -25EC2 / 00016 / 03016 / 04016 / 05016 | KH-25EC-P | 25 | 6.0 - 16 | 0 | 38 - 60 (65) | 36 | 44 | 35 | 80 | FDC-16 -OH or C | | |
| | | | 6.0 | 3.0 | | | | | | | | |
| | KH-26EC-P | 26 | 6.1 - 9.0 | 4.0 | 39 - 58 (63) | | | | | | | |
| | | | 9.1 - 12 | 5.0 | | | | | | | | |
| KHB -28EC2 / 00016 / 03016 / 04016 / 05016 | KH-28EC-P | 28 | 12.1 - 16 | 6.0 | 42 - 64 (69) | 46 | 47 | 40 | 100 | FDC-22 -OH or C | | 3MPa |
| | | | 6.0 - 22 | 0 | | | | | | | | |
| | KH-30EC-P | 30 | 6.0 - 22 | 3.0 | 47 - 69 (74) | | | | | | | |
| | | | 6.0 | 6.0 | | | | | | | | |
| KHB -32EC2 / 00022 / 03022 / 04022 / 05022 | KH-32EC-P | 32 | 6.0 - 22 | 0 | 38 - 74 | 46 | 51 | 40 | 100 | FDC-22 -OH or C | | |
| | | | 6.0 | 3.0 | | | | | | | | |
| | KH-35EC-P | 35 | 6.1 - 9.0 | 4.0 | 39 - 75 | | | | | | | |
| | | | 9.1 - 12 | 5.0 | | | | | | | | |
| KHB -36EC2 / 06022 / 08022 | KH-36EC-P | 36 | 12.1 - 16 | 6.0 | 42 - 78 | 46 | 55 | 40 | 100 | FDC-22 -OH or C | | |
| | | | 16.1 - 22 | 8.0 | | | | | | | | |
| | KH-36EC-P | 36 | 12.1 - 16 | 6.0 | 48 - 84 | | | | | | | |
| | | | 16.1 - 22 | 8.0 | | | | | | | | |

Ordering Example

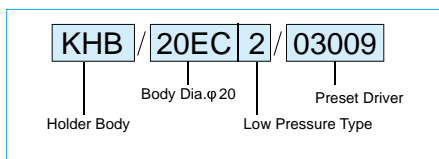

- All dimensions shown in millimeters.
- L₃ in brackets stands for the KHB-28EC2 and KH-30EC2 dimensions only.
- Coolant pin, coolant collet and spanner wrench are sold separately. (Page 60, 208)

Quick Change Stub Holder KH-EC

Coolant Pin

Ordering Example

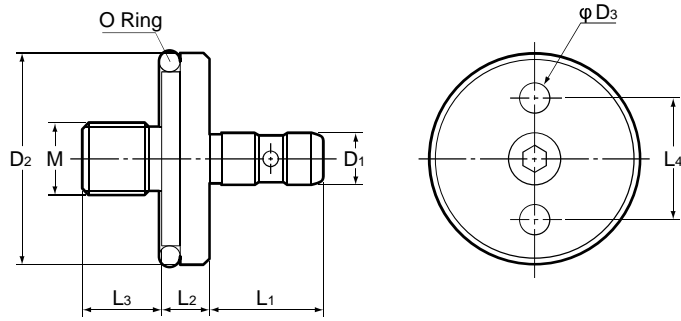
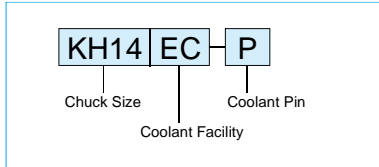

| Part Number | D ₁ | D ₂ | M | O Ring | L ₁ | L ₂ | L ₃ | L ₄ | D ₃ |
|-------------|----------------|----------------|---------|-----------|----------------|----------------|----------------|----------------|----------------|
| KH14EC-P | 5.7 | 13.9 | M 8 P=1 | P-10A 1-B | 15 | 8 | 13 | 9.6 | 3.5 |
| KH16EC-P | | 15.9 | | P-12 1-B | | | | 11 | |
| KH19EC-P | | 18.9 | | P-15 1-B | | | | 15.4 | |
| KH20EC-P | | 19.9 | | P-16 1-B | | | | | |
| KH22EC-P | 7.6 | 21.9 | M10 P=1 | P-18 1-B | 16.5 | 8 | 13 | 15.4 | 5.5 |
| KH24EC-P | | 23.9 | | P-20 1-B | | | | 17 | |
| KH25EC-P | 8.6 | 24.9 | M12 P=1 | P-21 1-B | 19 | 8 | 13 | | |
| KH26EC-P | | 25.9 | | P-22 1-B | | | | | |
| KH28EC-P | | 27.9 | | P-22A 1-B | | | | | |
| KH30EC-P | | 29.9 | | P-24 1-B | | | | 20 | |
| KH32EC-P | | 31.9 | | P-26 1-B | | | | | |
| KH35EC-P | | 34.9 | | P-29 1-B | | | | | |
| KH36EC-P | 35.9 | P-30 1-B | | | | | | | |

Model KH-EC Coolant Pin Wrench

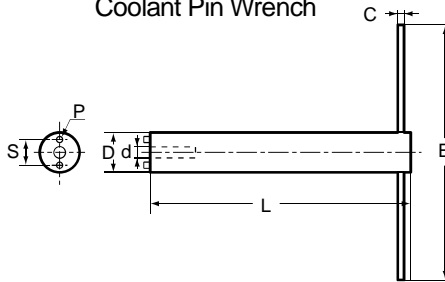

| Pin Wrench Model | Coolant Pin | d | D | S | P | L | C | E | |
|------------------|-------------|----------|------|------|------|-----|-----|-----|-----|
| HDMC | -14G | 6 | 13.5 | 9.6 | 3 | 120 | 6 | 120 | |
| | KH16EC-P | | | | | | | | |
| | -16G | KH19EC-P | 8 | 21.5 | 15.4 | 5 | 160 | 10 | |
| | | KH20EC-P | | | | | | | |
| | -22G | KH22EC-P | 9 | 24.5 | 17 | 5 | 180 | 12 | |
| | | KH24EC-P | | | | | | | |
| | -25G | KH25EC-P | 9 | 31.5 | 20 | 5 | 200 | 12 | 200 |
| | | KH26EC-P | | | | | | | |
| | | KH28EC-P | | | | | | | |
| | | KH30EC-P | | | | | | | |
| | -32G | KH32EC-P | | | | | | | |
| | | KH35EC-P | | | | | | | |
| | KH36EC-P | | | | | | | | |

• All dimensions shown in millimeters.

Quick Change Stub Holder

Spindle Standard for KH-EC

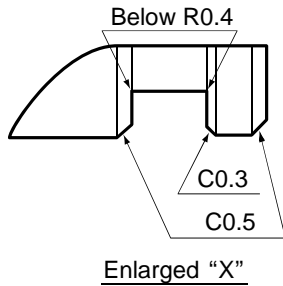
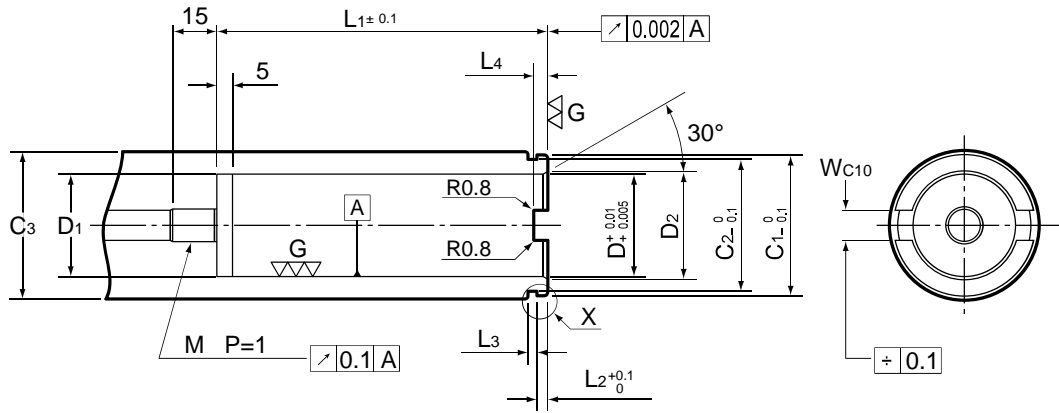

Note

- The material of the spindle face is SCM415. Heat treatment HV613-697. Carburized depth 0.4 - 0.6mm.

| Nominal Size | D +0.010 +0.005 | D ₁ | D ₂ | C ₁ 0 -0.1 | C ₂ 0 -0.1 | C ₃ | L ₁ | L ₂ ^{+0.1} ₀ | L ₃ | W C ₁₀ | L ₄ | M |
|--------------|-----------------------|----------------|----------------|-----------------------------|-----------------------------|----------------|----------------|---|----------------|----------------------|----------------|------------|
| 14EC | 14 | 14.4 | 15.5 | 22 | 20 | 20or more | 60 | 2.5 | 2.5 | 8 | 3.5 | M8 P=1 |
| 16EC | 16 | 16.4 | 17.5 | 29.4 | 27 | 28or more | 70 | 3.5 | 3.0 | | | |
| 19EC | 19 | 19.4 | 20.5 | | | | | | | | | |
| 20EC | 20 | 20.4 | 21.5 | 37.4 | 35 | 35or more | 91 | | | 10 | 4.5 | 10 |
| 22EC | 22 | 22.4 | 23.5 | | | | | 40.4 | 38 | | | |
| 24EC | 24 | 24.4 | 25.5 | 47.8 | 45 | 45or more | 111 | | | | | |
| 25EC | 25 | 25.4 | 26.5 | | | | | 47.8 | 45 | 45or more | 111 | M12 P=1 |
| 26EC | 26 | 26.4 | 27.5 | | | | | | | | | |
| 28EC | 28 | 28.4 | 29.5 | 47.8 | 45 | 45or more | 111 | M12 P=1 | | | | |
| 30EC | 30 | 30.4 | 31.5 | | | | | | | | | |
| 32EC | 32 | 32.4 | 33.5 | 47.8 | 45 | 45or more | 111 | M12 P=1 | | | | |
| 35EC | 35 | 35.4 | 36.5 | | | | | | | | | |
| 36EC | 36 | 36.4 | 37.5 | 47.8 | 45 | 45or more | 111 | M12 P=1 | | | | |

• All dimensions shown in millimeters.