

# TECHNICAL SECTION

## Shank dimensions (major)

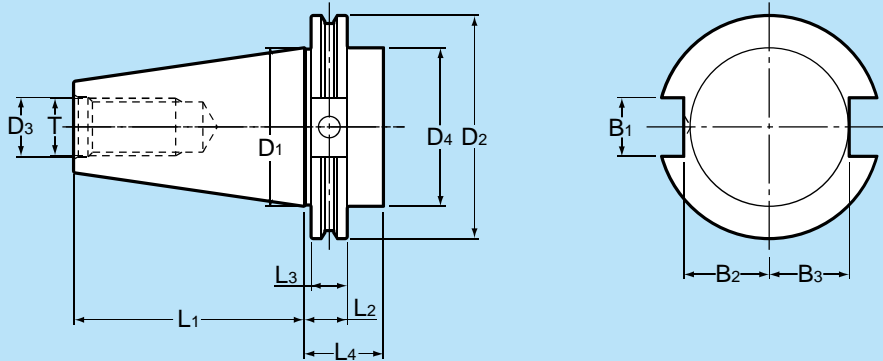

(unit : inch)

Shank size	D <sub>1</sub>	D <sub>2</sub>	D <sub>3</sub>	D <sub>4</sub>	T	L <sub>1</sub>	L <sub>2</sub>	L <sub>3</sub>	L <sub>4</sub>	B <sub>1</sub>	B <sub>2</sub>	B <sub>3</sub>
CAT40	1.750	2.500	0.641	1.750	0.625-11	2.687	0.625	0.750	1.38Min.	0.645	0.985	0.890
CAT50	2.750	3.875	1.031	2.750	1.000-8	4.000	0.625	0.750	1.38Min.	1.020	1.485	1.390

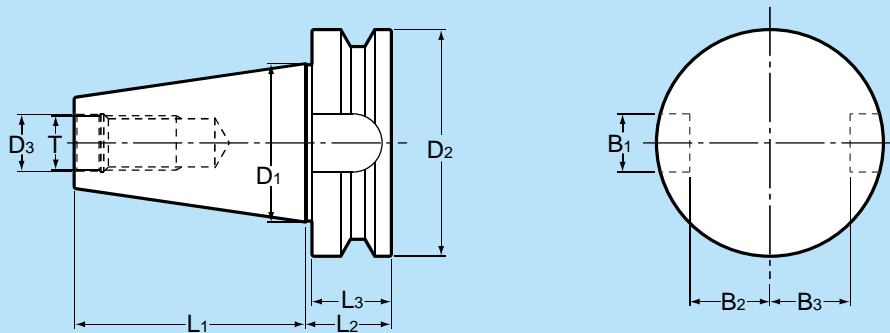

(unit : inch)

Shank size	D <sub>1</sub>	D <sub>2</sub>	D <sub>3</sub>	D <sub>4</sub>	T	L <sub>1</sub>	L <sub>2</sub>	L <sub>3</sub>	L <sub>4</sub>	B <sub>1</sub>	B <sub>2</sub>	B <sub>3</sub>
BT30	1.250	1.811	0.492	—	M12	1.906	0.866	0.787	—	0.634	0.642	0.642
BT40	1.750	2.480	0.669	—	M16	2.575	1.063	0.984	—	0.634	0.886	0.886
BT50	2.750	3.937	0.984	—	M24	4.008	1.496	1.378	—	1.012	1.390	1.390

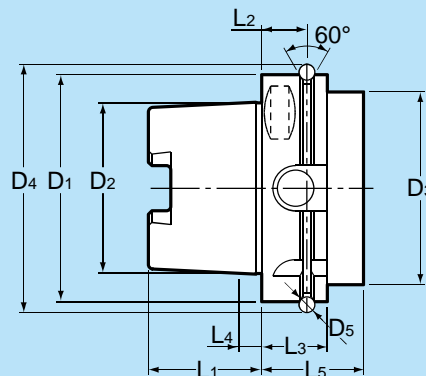

(unit : inch)

Shank size	D <sub>1</sub>	D <sub>2</sub>	D <sub>3</sub> (Max.)	D <sub>4</sub>	D <sub>5</sub>	L <sub>1</sub>	L <sub>2</sub>	L <sub>3</sub>	L <sub>4</sub>	L <sub>5</sub>
HSK 40A	1.575	1.496	1.339	1.772	0.157	0.787	0.630	0.787	0.157	1.378
HSK 63A	2.480	1.890	2.087	2.846	0.276	1.260	0.709	1.024	0.248	1.654
HSK100A	3.937	2.953	3.465	4.321	0.276	1.969	0.787	1.142	0.394	1.772