

# Retention Studs CT Taper

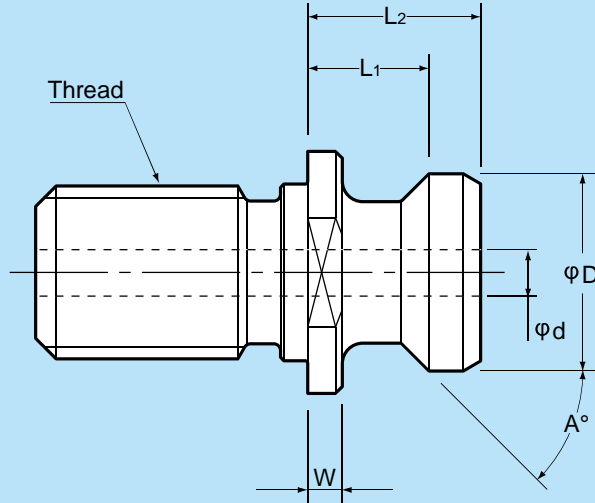

## ■ CT Taper Retention Studs

Part Number	D	L <sub>1</sub>	L <sub>2</sub>	Angle	W	Thread	d	Shank size	Description
PSC40-1	0.74	0.440	0.64	45°	0.12	5/8"-11	0.275	CAT40	ANSI Standard , With a coolant hole
PSC50-1	1.14	0.700	1.00	45°	0.20	1"-8	0.464	CAT50	ANSI Standard , With a coolant hole

Please provide us with the following information when ordering studs:

- \*Your machining center's taper size and flange type (CAT40, CAT50, BT40 etc.).
- \*The brand name of your machining center
- \*The model number

Please have these dimensions ready when you place your order , so that we may quickly determine which retention stud is needed for your machining center.

# Retention Studs BT Taper

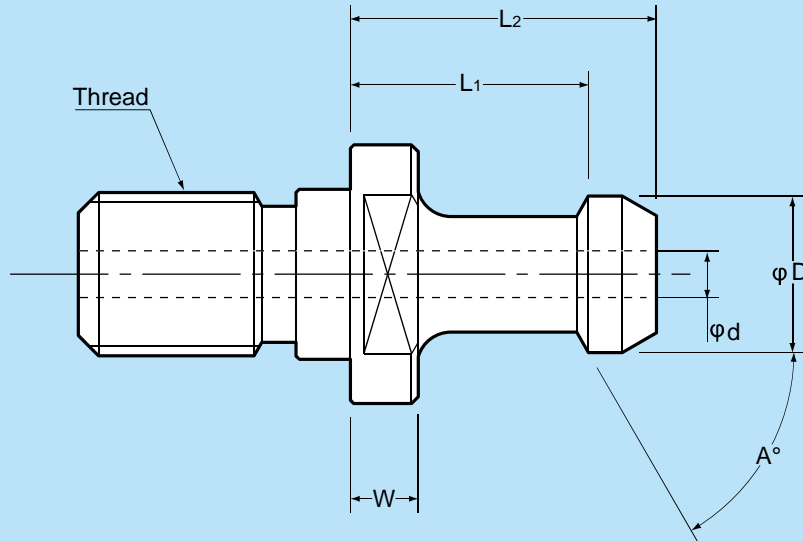

## ■ BT Taper Retention Studs

Part Number	D	L <sub>1</sub>	L <sub>2</sub>	Angle	W	Thread	d	Shank size	Description
PSB-0	0.433	0.709	0.906	45°	0.197	M12	-	BT30	MAS P30T1
PSB-0A				60°					MAS P30T2
PSB-3	0.591	1.102	1.378	45°	0.236	M16	0.157	BT40	MAS P40T1
PSB-3-CH				60°					With a coolant hole
PSB-4									MAS P40T2
PSB-4-CH	0.157	With a coolant hole							
PSB-7	0.906	1.378	1.772	45°	0.394	M24	-	BT50	MAS P50T1
PSB-7-CH				60°					With a coolant hole
PSB-8									MAS P50T2
PSB-8-CH	0.236	With a coolant hole							
PSB-11	0.591	1.102	1.378	90°	0.236	M16	-	BT40	
PSB-15	0.866	2.480	2.874	45°	1.457	-	-	BT50	
PSB-19	0.906	1.378	1.772	90°	0.394	M24	-		
PSB-23	0.740	0.551	0.752	45°	0.118	M16	0.275	BT40	
PSB-24	1.142	0.689	0.992		0.197	M24	0.393	BT50	
PSB-30P	0.472	0.724	0.921	75°	0.197	M12	0.157	BT30	JIS 30P,With a coolant hole
PSB-40P	0.748	0.906	1.142		M16	0.275	BT40	JIS 40P,With a coolant hole	
PSB-50P	1.102	0.984	1.339		M24	0.393	BT50	JIS 50P,With a coolant hole	

Please provide us with the following information when ordering studs:

\*Your machining center's taper size and flange type (CAT40, CAT50, BT40 etc.).

\*The brand name of your machining center

\*The model number

Please have these dimensions ready when you place your order, so that we may quickly determine which retention stud is needed for your machining center.