

Tool Presetter NTP

NTP - 300A

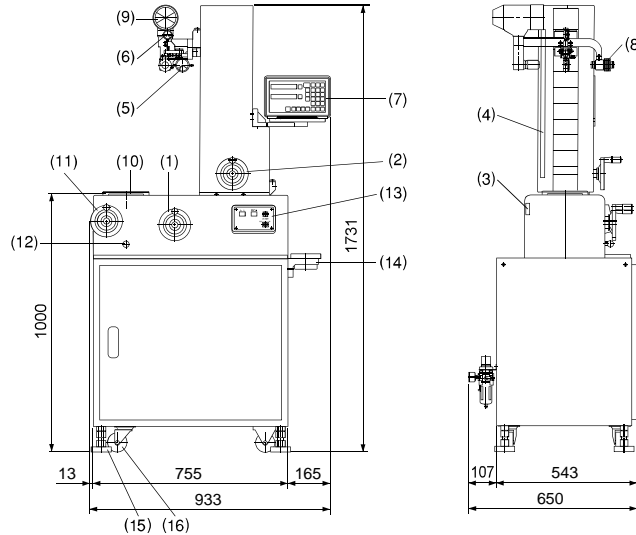

- (1) X-axis handle
- (2) Z-axis handle
- (3) X-axis scale
- (4) Z-axis scale
- (5) X-axis dial gauge
- (6) Z-axis dial gauge
- (7) Digital display
- (8) Optical projector (Light source unit)
- (9) Optical projector (Projecting unit)
- (10) Spindle
- (11) Spindle turning handle
- (12) Spindle fixing knob
- (13) Control panel
- (14) Tool setting pot
- (15) Level bolts
- (16) Casters

NTP - 400

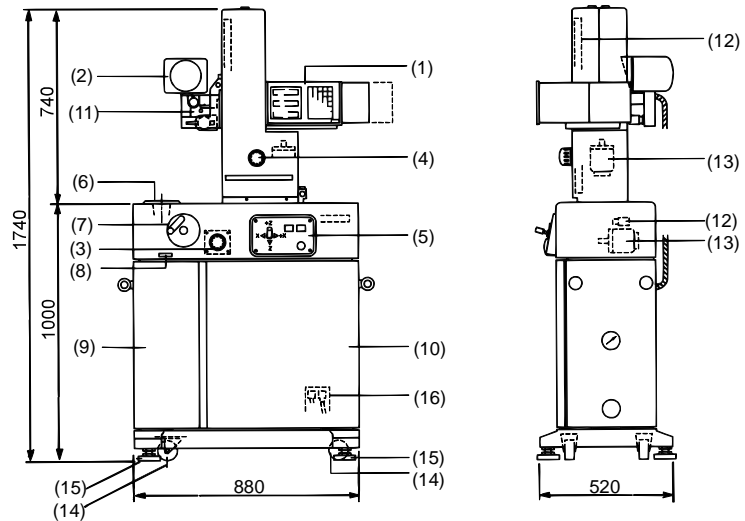



- (1) Digital display
- (2) Optical projector
- (3) X-axis handle
- (4) Z-axis handle
- (5) Control panel
- (6) Spindle
- (7) Spindle turning handle
- (8) Spindle fixing knob
- (9) Air cylinder storage unit
- (10) Accessory storage unit
- (11) Dial gauge for X,Z-axis
- (12) Scale for X,Z-axis
- (13) Motor for X,Z-axis
- (14) Casters
- (15) Level bolts
- (16) Connecting unit

Feature

One presetter can measure various kinds of shanks with taper reduction parts.
(Please see page 182 as for detail.)

Tool Presetter NTP

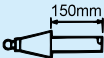
		NTP- 300A	NTP- 400
Measurement range	X axis (Tool diameter) Z axis (tool length)	D=0 - ϕ 300mm L=50 - 500mm	D=0 - ϕ 400mm L=50 - 500mm
Min. readable unit	X-axis	Digital display ϕ 0.002mm (Diameter) or 0.001mm (Radius)	
	Z-axis	Digital display 0.005mm	
Dial gauge	 1 division	X-axis 0.001mm Z-axis 0.01mm	
Spindle shank	 Spindle	BT30 - BT50 HSK32 - HSK100	
Master gauge	 150mm	Including one 150mm gauge as standard accessory.	
Column movement method		Handle (Manual)	Lever (Moter drive)
Power supply		AC100V \pm 10% 50/60Hz If voltage exceeds AC 100V, please specify when ordering.	
Pneumatic supply	For auto tool lock	0.4 - 0.7MPa	
Weight		350kg	400kg
Standard accessories		Wrench set, Taper cleaner, Cover set, Lamp, Operating manual, Pedestal, Precision table, Spanner	

Digital display	
A : Standard	B : with RS232C

Retention stud		
MAS I	MAS II	Others

●Tool presetter with digital display B type is quoted upon request.

●When ordering others, please specify.

Ordering Example NTP-300A-A-BT40-2