

# Shrink Fit Heating System

## Magnetic Induction Heating Device

### IH1500

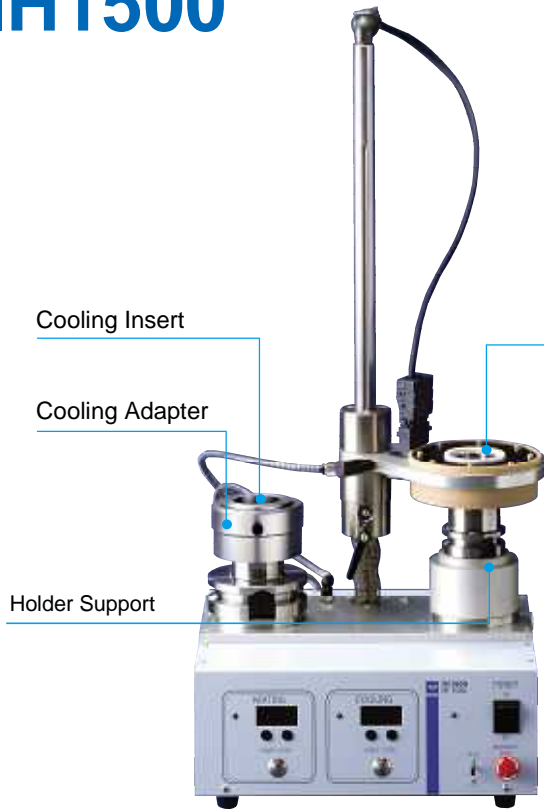

- Holders in a variety of sizes from short to long can be heated.
- Regardless of the material of holder, products from other companies can also be heated. (Nonmagnetic steel holders can also be heated.)
- Heating and cooling work can be performed at the same time.
- Cutting tool with shank diameters of 3-32 can be attached and removed.

It is possible to use for holder with short projection lengths by adopting a thin magnetic coil.

Holder with short projection length (projection length 45mm) can be attached and removed by adopting the world's smallest thin magnetic coil (27mm).

\*Holder support extension table is required when a holder with less than projection length of 55mm is attached and removed.

\*Can only be used when a magnetic coil with an inside diameter of 20 or 28 is used.

Comparison of projection lengths

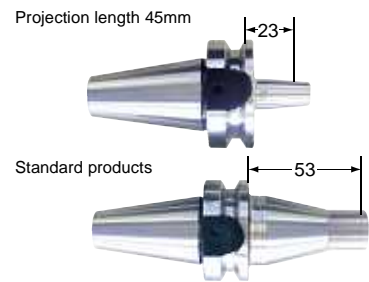

## Magnetic Induction Heating Device

### IH3200-N

Heating Coil  
Heating time: 5 sec

Cooling Adaptor  
Cooling time: 60 sec

Magnetic Induction Heating Device  
IH3200-N

Cooling Device  
SRK-C3A

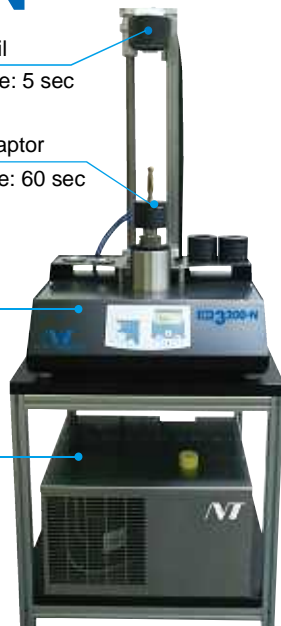

\*Table is not included.

## Hot air type heating device

### SRK-HA1 (100V)

### SRK-HB2 (200V, 230V)



- Space-saving design
- Affordable price
- Operated by 100V(1200w)/ 200V, 230V(3000W)
- No need for air piping

# Shrink Fit Heating System IH1500

### Cooling Insert (option)

An insert for a cooling adapter.

### Cooling adapter (include)

An adapter for a cooling insert.  
\*For SRK32A, please purchase a dedicated adapter separately.

### Easily adjustable timer

Heating and cooling time setting is digitally displayed. Heating time ranges from 1 to 199 seconds, and cooling time ranges from 1 to 999 seconds.

Time range	
Heating time	1 to 199 second
Cooling time	1 to 999 second

### Feature

Regardless of the material of holder, products from other companies can also be heated.  
(Nonmagnetic steel holders can also be heated.)

Heating and cooling work can be performed at the same time.

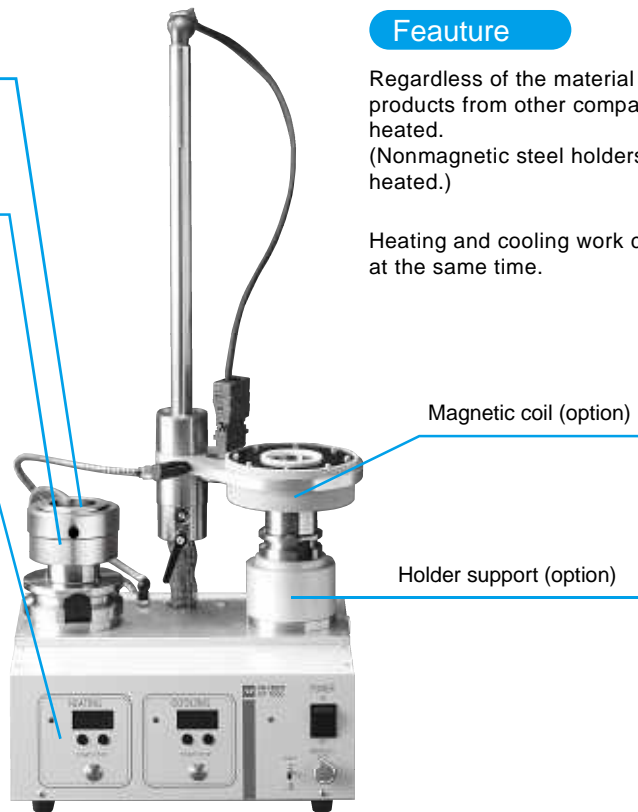

### Specifications

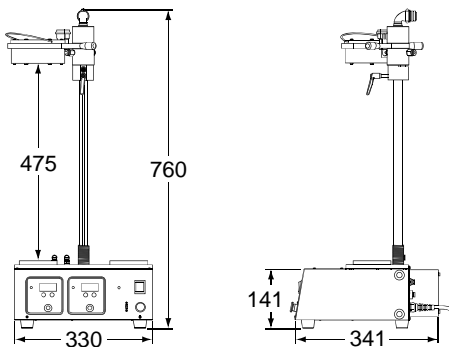

Model	IH1500
External dimensions	L341xW330xH760
Code	3065 00001500
Output	1500W
Weight	11Kg
Chucking range of holder	φ3.0 - φ32.0mm (The magnetic coil must be changed.)
Cooling method	Cooling by air

Air pressure	0.3 - 0.7MPa
Connecting air hose(OD=6.0mm/ID=4.0mm) should be prepared. Air filters and lubricators should be used in case there is much moisture in the compressed air.	

Power supply(1.6m)	100VAC 50-60Hz (single phase)
This is a three-pronged plug. Please use an outlet for three-pronged plugs.	

Tool plate (Main spindle shank size)	BT50×2
Please separately purchase a holder support when using a holder other than BT50. In addition, a holder support for BT50 is required for a BT50 holder with projection length of less than 120mm.	

- Cooling adapter (IH1500-CA) and heat-resistant glove (T6-8253-01J) are included. Please separately order the magnetic coil, cooling insert, holder support and holder support extension table.
- Please order FGB1-15A when replacing fuses.

# Shrink Fit Heating System IH1500 Accessories

## Magnetic coil (option)



For efficient heating, please select an adaptable minimum coil size.

- \*Coil thickness
- 20,28 - - - - - 27mm
  - 35,42,52 - - - - - 42mm
  - 70 - - - - - 55mm

Model	Adaptable NT holder		
	SRS	SRD	SRE
IH1500	-20	-	SRS3A - SRS8A
	-28	SRS6A - SRS8A	-
	-35	SRS6A - SRS20A	SRD6A - SRD12A
	-42	SRS6A - SRS20A	SRD6A - SRD20A
	-52	SRS6A - SRS20A	SRD6A - SRD20A
	-70	SRS10A - SRS20A	SRD10A - SRD32A

## Holder support (option)



Holder support for BT50 is required for a BT50 holder with projection length of less than 120mm.

Model	Adaptable shank size								
	30	BT			HSK				
		40	50	25	32	40	50	63	100
IH1500-SPH	-BT40- 30	●	●						
	-BT50			●					
	-HSK32- 25				●	●			
	-HSK40- 32					●	●		
	-HSK50- 40						●	●	
	-HSK63- 40						●		●
	-HSK100								

## Holder support extension table (option)



IH1500-SPK

When a holder with a length of less than 55mm is used, the magnetic coil does not reach. Please use a holder support extension table in such cases.

## Cooling Adapter



IH1500-CA

\*IH1500-CA is included in main system.

## Coolant Insert (option)



Holder size	Model
6A	IH1500-SRS6A
8A	IH1500-SRS8A
10A	IH1500-SRS10A
12A	IH1500-SRS12A
16A	IH1500-SRS16A
20A	IH1500-SRS20A

Holder size	Model
6A	IH1500-SRD6A-8A
8A	IH1500-SRD10A-12A
10A	IH1500-SRD10A-12A
12A	IH1500-SRD10A-12A
14A	IH1500-SRD14A-16A
16A	IH1500-SRD14A-16A
18A	IH1500-SRD18A-20A
20A	IH1500-SRD18A-20A
25A	IH1500-SRD25A-32A
32A	IH1500-SRD25A-32A

Holder size	Model
3A	IH1500-SRE3A-4A
4A	
5A	IH1500-SRE5A-6A-8A
6A	
8A	