

HSK Tightening Fixture

SPN1-HSK40A/63A/100A



Features

Easy to use

To clamp the holder, insert the HSK shank and rotate the knob 90 degrees.

Taper shank will be securely clamped with perfect face contact. Tool chucking can be done without damaging the 1/10 taper face.

Tool length measurement possible

Can be used for tool length presetting

Two different types available

Type SPN1 : with clamp base

Type PH : Holder support only

Applications

Suitable for tightening milling chucks or collet chucks.

Tool presetting for length measurement.



HSK Tightning Fixture SPN / HSK

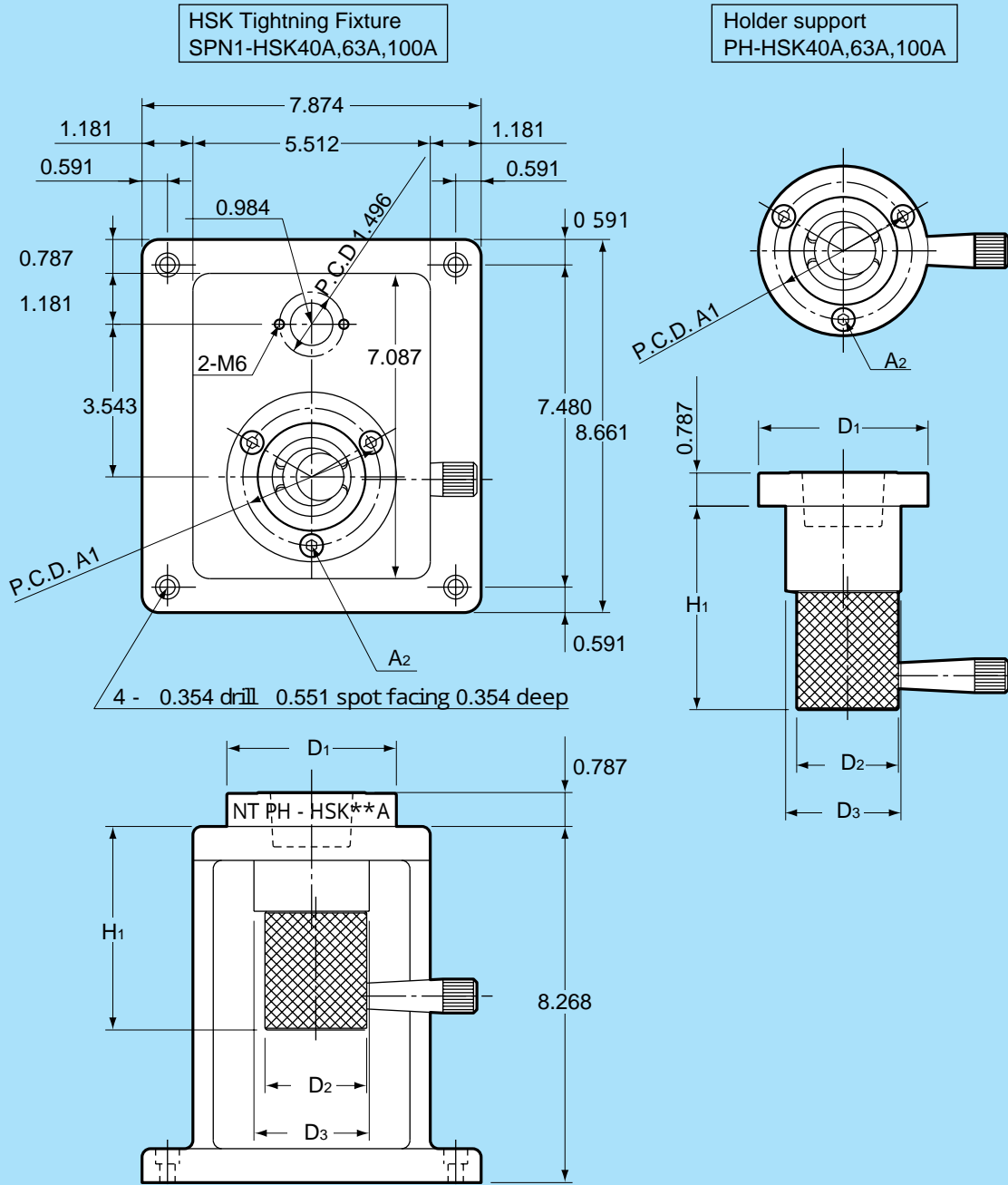

HSK Tightning Fixture SPN/HSK

Part Number	D ₁	D ₂	D ₃	H ₁	A ₁	A ₂
SPN1-HSK 40A	3.150	1.850	2.126	5.000	2.559	3-M6
SPN1-HSK 63A	4.646	2.362	3.346	4.921	4.016	3-M8
SPN1-HSK100A				5.709		

Ordering examples

Complete with clamp

SPN1-HSK 40A
SPN1-HSK 63A
SPN1-HSK100A

*HSK-C type can be also used.
*Other sizes available on request

Holder support

PH-HSK 40A
PH-HSK 63A
PH-HSK100A