

# GDC Collet Chucks

Designed for high speed applications. GDC collet chucks incorporate balancing screws which are adjusted to achieve required balancing grades for high speed applications. Use with compatible balancing machines and NT's FDC collet system.

## Balanced type **GDC-A**



GDC Type	Max Imbalance Value
BT30	1.0 gmm
BT40	2.0 gmm
BT50	5.2 gmm
HSK-63-A	2.0 gmm
HSK-100-A	5.2 gmm
CAT40	2.0 gmm
CAT50	5.2 gmm

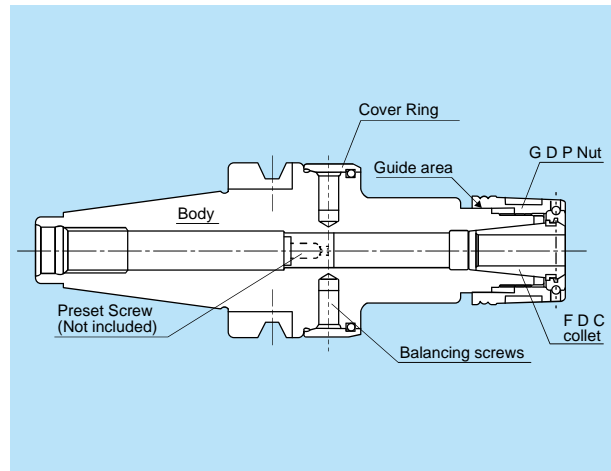

### ■ Features

#### ● Truly balanced Holder

Pre balanced holders ready to use straight out of the box.

#### ● Machining at High R.P.M.

The NT balanced collet holder (GDC) is designed for use in incredibly high speed (40,000rpm) applications.

#### ● Extended Life of Cutting Tool

Balanced tool holders extends the life of cutting tool and produces better surface finishes.

#### ● Center-thru Coolant Feed

All 3 types are designed for center-thru coolant feed.

### ■ Applications

High R.P.M. machining for drilling, reaming and finish endmilling.

Model no.	Preset screw no.	Clamping torque	Spanner Size
GDC 07	HDS-07	8-11 lbf-ft (89 - 133 lbf-in)	S-0
GDC 09	HDS-09	22-26 lbf-ft (266 - 310 lbf-in)	FK0025
GDC 12	HDS-12	26 - 30 lbf-ft (310 - 354 lbf-in)	FK0030
GDC 16	HDS-16	30 - 33 lbf-ft (354 - 398 lbf-in)	FK0034
GDC 22	HDS-22	41 - 44 lbf-ft (487 - 531 lbf-in)	FK0045

### Coolant supply



Cutter with oil hole  
**FDC-OH type**

R.P.M. .... 8,000rpm

Coolant  
Pressure ..... 870psi



Cutter without oil hole  
**FDC-C type**

R.P.M. .... 8,000rpm

Coolant  
Pressure ..... 870psi

# High-Precision Collet Chucks CAT / GDC · A

**Type 1**

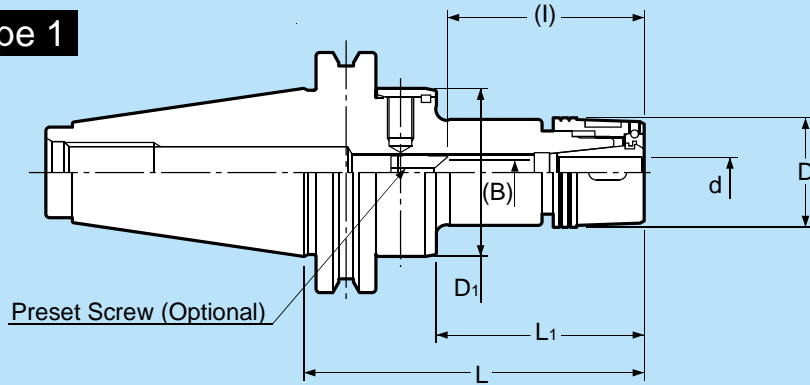

**Type 2**

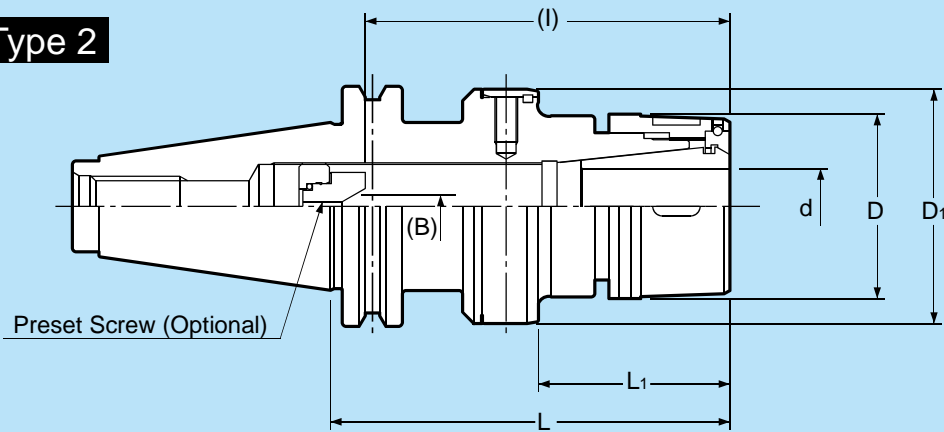

Part Number	Type	d	L	L <sub>1</sub>	(B)	(l)	D	D <sub>1</sub>	Preset Screw	Nut	Collet	Spanner
CAT40	1	-GDC07A -90 -120	3.543	2.165	0.0 - 0.157	0.866 - 1.772	0.906	1.750	HDS-07	HDP-07A	FDC-07AA	S-0
			4.724	3.346								
		-GDC09A -90 -120	3.543	2.165	0.0 - 0.157	1.063 - 2.244	1.142					
	4.724		3.346									
	2	-GDC12A -105 -135	4.134	2.756	0.0 - 0.197	1.299 - 2.677	1.339					
			5.315	3.937								
-GDC16A -105 -135		4.134	2.756	0.0 - 0.236	1.496 - 3.189	1.496						
5.315	3.937											
-GDC22A -105 -135	0.138 - 0.866	4.134	1.969	0.0 - 0.315	1.850 - 4.055	1.929	2.441	HDS-22	GDP-22	FDC-22AA	FK0045	
CAT50	1	-GDC07A -105 -135	4.134	2.756	0.0 - 0.157	0.866 - 1.772	0.906	2.750	HDS-07	HDP-07A	FDC-07AA	S-0
			5.315	3.937								
		-GDC09A -105 -135	4.134	2.756	0.0 - 0.157	1.063 - 2.244	1.142					
	5.315		3.937									
	2	-GDC12A -105 -135	4.134	2.756	0.0 - 0.197	1.299 - 2.677	1.339					
			5.315	3.937								
-GDC16A -105 -135		4.134	2.756	0.0 - 0.236	1.496 - 3.189	1.496						
5.315	3.937											
-GDC22A -105 -135	0.138 - 0.866	4.134	2.756	0.0 - 0.315	1.850 - 4.055	1.929		HDS-22	GDP-22	FDC-22AA	FK0045	

## Ordering Example CAT40-GDC12A-105

- Collet, spanner wrench and preset screw (page 55 - 61) are sold separately.
- Use class "AA" collet only.

# High-Precision Collet Chucks

## BT / GDC • A High Balanced Type

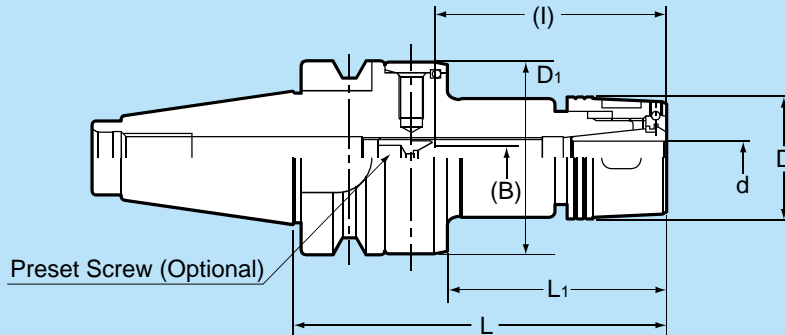

Part Number	d	L	L <sub>1</sub>	(B)	(I)	D	D <sub>1</sub>	Preset Screw	Nut	Collet	Spanner
BT30	-GDC07A	-90	3.543	2.087	0.0-0.157	0.866-1.772	0.906	HDS-07	HDP-07A	FDC-07AA	S-0
		-105	4.134	2.677							
	-GDC09A	-90	3.543	2.087	0.0-0.157	1.063-2.244	1.142				
		-105	4.134	2.677							
BT30	-GDC12A	-90	3.543	2.087	0.0-0.197	1.299-2.677	1.339	HDS-12	GDP-12	FDC-12AA	FK0030
		-105	4.134	2.677							
	-GDC16A	-90	3.543	2.087	0.0-0.236	1.496-3.189	1.496				
		-120	4.724	3.268							
BT40	-GDC07A	-90	3.543	1.890	0.0-0.157	0.866-1.772	0.906	HDS-07	HDP-07A	FDC-07AA	S-0
		-120	4.724	3.071							
	-GDC09A	-90	3.543	1.890	0.0-0.157	1.063-2.244	1.142				
		-120	4.724	3.071							
	-GDC12A	-90	3.543	1.890	0.0-0.197	1.299-2.677	1.339				
		-120	4.724	3.071							
-GDC16A	-90	3.543	1.890	0.0-0.236	1.496-3.189	1.496					
	-120	4.724	3.071								
BT40	-GDC22A	-90	3.543	1.890	0.0-0.315	1.850-4.055	1.929	HDS-22	GDP-22	FDC-22AA	FK0045
		-105	4.134	2.480							
	-135	5.315	3.661								
BT50	-GDC07A	-105	4.134	2.047	0.0-0.157	0.866-1.772	0.906	HDS-07	HDP-07A	FDC-07AA	S-0
		-135	5.315	3.228							
	-GDC09A	-105	4.134	2.047	0.0-0.157	1.063-2.244	1.142				
		-135	5.315	3.228							
	-GDC12A	-105	4.134	2.047	0.0-0.197	1.299-2.677	1.339				
		-135	5.315	3.228							
-GDC16A	-105	4.134	2.047	0.0-0.236	1.496-3.189	1.496					
	-135	5.315	3.228								
-GDC22A	-105	4.134	2.047	0.0-0.315	1.850-4.055	1.929	HDS-22	GDP-22	FDC-22AA	FK0045	
-135	5.315	3.228									

### Ordering Example BT40-GDC12A-120

- Collet, spanner wrench and preset screw (page 55 - 61) are sold separately.
- Use class "AA" collet only.

# High-Precision Collet Chucks

## HSK / GDC • A High Balanced Type

**Type 1**

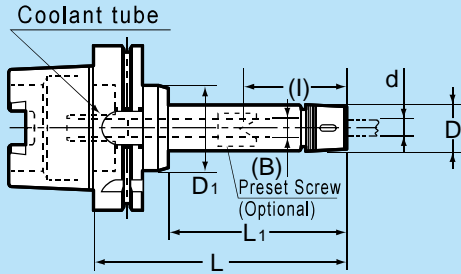

**Type 2**

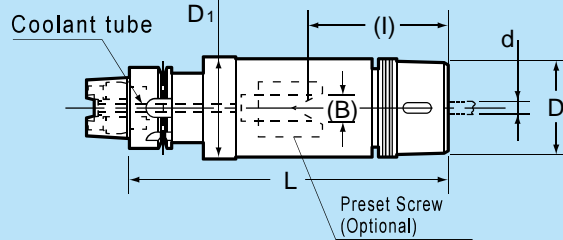

Part Number	Type	d	L	L <sub>1</sub>	(B)	(I)	D	D <sub>1</sub>	Preset Screw	Nut	Collet	Spanner				
HSK40A	1	-75	2.953	1.575	-	0.866 - 1.142	-	-	HDS-07	HDP-07A	FDC-07AA	S-0				
		-90	3.543	2.165	0.0 - 0.157	0.866 - 1.732	0.906									
		-120	4.724	3.346	-	0.866 - 1.772	-									
	2	-75	2.953	1.575	-	-	1.063	-	HDS-09	GDP-09	FDC-09AA	FK0025				
		-90	3.543	2.165	0.0 - 0.157	1.063 - 1.575	1.142									
		-120	4.724	3.346	-	1.063 - 2.244	-									
		-90	3.543	-	-	1.614	-	HDS-12					GDP-12	FDC-12AA	FK0030	
		-120	4.724	0.0 - 0.197	1.299 - 1.811	1.339	1.535									
		-150	5.906	-	1.299 - 3.031	-	-									
		-90	3.543	-	-	1.575	-	HDS-16					GDP-16	FDC-16AA	FK0034	
		-120	4.724	0.0 - 0.236	1.496 - 1.772	1.496	1.654									
		-150	5.906	-	1.496 - 2.874	-	-									
-120	4.724	-	-	2.677	-	HDS-22	GDP-22	FDC-22AA	FK0045							
-150	5.906	0.0 - 0.315	1.850 - 2.953	1.929	1.929											
HSK63A	1	-75	2.953	1.339	-	0.866 - 1.339	-	-	HDS-07	HDP-07A	FDC-07AA	S-0				
		-90	3.543	1.929	0.0 - 0.157	0.866 - 1.772	0.906									
		-120	4.724	3.110	-	-	-									
	2	-75	2.953	1.339	-	-	1.063 - 1.339	-	HDS-09	GDP-09	FDC-09AA	FK0025				
		-90	3.543	1.929	0.0 - 0.157	1.063 - 1.654	1.142									
		-120	4.724	3.110	-	1.063 - 2.244	-									
		-90	3.543	1.929	-	2.047	-	HDS-12					GDP-12	FDC-12AA	FK0030	
		-120	4.724	3.110	0.0 - 0.197	1.299 - 2.323	1.339									2.047
		-150	5.906	4.291	-	1.299 - 3.031	-									-
		-90	3.543	1.929	-	2.362	-	HDS-16					GDP-16	FDC-16AA	FK0034	
		-120	4.724	3.110	0.0 - 0.236	1.496 - 2.283	1.496									
		-150	5.906	4.291	-	1.496 - 3.189	-									-
-90	3.543	1.929	-	2.480	-	HDS-22	GDP-22	FDC-22AA	FK0045							
-120	4.724	3.110	0.0 - 0.315	1.850 - 2.204	1.929											
-150	5.906	4.291	-	1.850 - 3.385	-	-										
HSK100A	1	-75	2.953	1.220	-	0.866 - 1.024	-	-	HDS-07	HDP-07A	FDC-07AA	S-0				
		-90	3.543	1.811	0.0 - 0.157	0.866 - 1.772	0.906									
		-120	4.724	2.992	-	-	-									
	2	-75	2.953	1.220	-	-	1.063	-	HDS-09	GDP-09	FDC-09AA	FK0025				
		-90	3.543	1.811	0.0 - 0.157	1.063 - 1.654	1.142									
		-120	4.724	2.992	-	1.063 - 2.244	-									
		-90	3.543	1.811	-	2.047	-	HDS-12					GDP-12	FDC-12AA	FK0030	
		-120	4.724	2.992	0.0 - 0.197	1.299 - 2.323	1.339									3.307
		-150	5.906	4.173	-	1.299 - 3.031	-									-
		-90	3.543	1.811	-	1.496 - 1.575	-	HDS-16					GDP-16	FDC-16AA	FK0034	
		-120	4.724	2.992	0.0 - 0.236	1.496 - 2.402	1.496									
		-150	5.906	4.173	-	1.496 - 3.189	-									-
-90	3.543	1.811	-	2.244	-	HDS-22	GDP-22	FDC-22AA	FK0045							
-120	4.724	2.992	0.0 - 0.315	1.850 - 2.244	1.929											
-150	5.906	4.173	-	1.850 - 3.268	-	-										

**Ordering Example** HSK63A-GDC12A-120

- Collet, spanner wrench and preset screw (page 55 - 61) are sold separately.
- Use class "AA" collet only.